

A
B
C

SECTION **GW**

GLASS & WINDOW SYSTEM

CONTENTS

| | | | | |
|--|----|---------------------------------|----|----|
| PRECAUTION | 2 | Inspection | 25 | F |
| PRECAUTIONS | 2 | REAR WINDOW GLASS | 26 | |
| Precaution for Supplemental Restraint System (SRS) "AIR BAG" and "SEAT BELT PRE-TENSIONER" | 2 | Exploded View | 26 | G |
| Precaution for Procedure without Cowl Top Cover..... | 2 | Removal and Installation | 27 | |
| Precautions for Removing Battery Terminal | 2 | Inspection | 34 | |
| Handling for Adhesive and Primer | 3 | FRONT DOOR GLASS | 35 | H |
| PREPARATION | 4 | Exploded View | 35 | |
| PREPARATION | 4 | Removal and Installation | 35 | |
| Special Service Tools | 4 | Inspection and Adjustment | 37 | I |
| Commercial Service Tools | 4 | FRONT REGULATOR | 38 | |
| SYMPTOM DIAGNOSIS | 5 | Exploded View | 38 | J |
| SQUEAK AND RATTLE TROUBLE DIAGNOSES | 5 | Removal and Installation | 38 | |
| Work Flow | 5 | Disassembly and Assembly | 40 | |
| Inspection Procedure | 7 | Inspection and Adjustment | 40 | |
| Diagnostic Worksheet | 9 | REAR DOOR GLASS | 41 | GW |
| REMOVAL AND INSTALLATION | 11 | Exploded View | 41 | |
| WINDSHIELD GLASS | 11 | Removal and Installation | 41 | L |
| Exploded View | 11 | Inspection and Adjustment | 44 | |
| Removal and Installation | 12 | REAR REGULATOR | 45 | |
| | | Exploded View | 45 | M |
| | | Removal and Installation | 45 | |
| | | Disassembly and Assembly | 46 | |
| | | Inspection and Adjustment | 47 | N |

PRECAUTIONS

< PRECAUTION >

PRECAUTION

PRECAUTIONS

Precaution for Supplemental Restraint System (SRS) "AIR BAG" and "SEAT BELT PRE-TENSIONER"

INFOID:000000012794159

The Supplemental Restraint System such as "AIR BAG" and "SEAT BELT PRE-TENSIONER", used along with a front seat belt, helps to reduce the risk or severity of injury to the driver and front passenger for certain types of collision. This system includes seat belt switch inputs and dual stage front air bag modules. The SRS system uses the seat belt switches to determine the front air bag deployment, and may only deploy one front air bag, depending on the severity of a collision and whether the front occupants are belted or unbelted. Information necessary to service the system safely is included in the "SRS AIR BAG" and "SEAT BELT" of this Service Manual.

WARNING:

Always observe the following items for preventing accidental activation.

- To avoid rendering the SRS inoperative, which could increase the risk of personal injury or death in the event of a collision that would result in air bag inflation, it is recommended that all maintenance and repair be performed by an authorized NISSAN/INFINITI dealer.
- Improper repair, including incorrect removal and installation of the SRS, can lead to personal injury caused by unintentional activation of the system. For removal of Spiral Cable and Air Bag Module, see "SRS AIR BAG".
- Never use electrical test equipment on any circuit related to the SRS unless instructed to in this Service Manual. SRS wiring harnesses can be identified by yellow and/or orange harnesses or harness connectors.

PRECAUTIONS WHEN USING POWER TOOLS (AIR OR ELECTRIC) AND HAMMERS

WARNING:

Always observe the following items for preventing accidental activation.

- When working near the Air Bag Diagnosis Sensor Unit or other Air Bag System sensors with the ignition ON or engine running, never use air or electric power tools or strike near the sensor(s) with a hammer. Heavy vibration could activate the sensor(s) and deploy the air bag(s), possibly causing serious injury.
- When using air or electric power tools or hammers, always switch the ignition OFF, disconnect the battery or batteries, and wait at least 3 minutes before performing any service.

Precaution for Procedure without Cowl Top Cover

INFOID:000000012794160

When performing the procedure after removing cowl top cover, cover the lower end of windshield with urethane, etc to prevent damage to windshield.

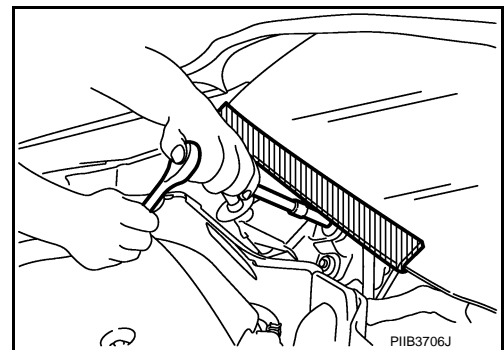

Precautions for Removing Battery Terminal

INFOID:000000013527759

When disconnecting the battery terminal, pay attention to the following.

- Always use a 12V battery as power source.
- Never disconnect battery terminal while engine is running.

PRECAUTIONS

< PRECAUTION >

- When removing the 12V battery terminal, turn OFF the ignition switch and wait at least 30 seconds.
- For vehicles with the engine listed below, remove the battery terminal after a lapse of the specified time:

| | | | |
|------------|--------------|------------|--------------|
| BR08DE | : 4 minutes | V9X engine | : 4 minutes |
| D4D engine | : 20 minutes | YD25DDTi | : 2 minutes |
| HR09DET | : 12 minutes | YS23DDT | : 4 minutes |
| HRA2DDT | : 12 minutes | YS23DDTT | : 4 minutes |
| K9K engine | : 4 minutes | ZD30DDTi | : 60 seconds |
| M9R engine | : 4 minutes | ZD30DDTT | : 60 seconds |
| R9M engine | : 4 minutes | | |

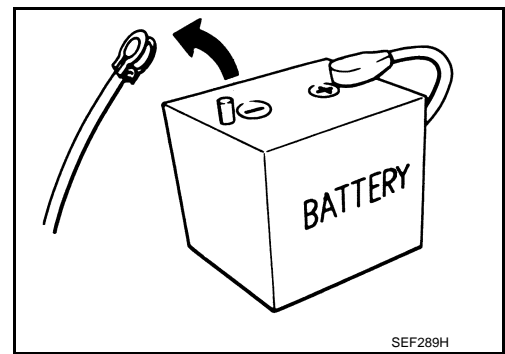

A
B
C
D
E
F
G
H
I
J
GW
L
M
N
O
P

NOTE:

ECU may be active for several tens of seconds after the ignition switch is turned OFF. If the battery terminal is removed before ECU stops, then a DTC detection error or ECU data corruption may occur.

- After high-load driving, if the vehicle is equipped with the V9X engine, turn the ignition switch OFF and wait for at least 15 minutes to remove the battery terminal.

NOTE:

- Turbocharger cooling pump may operate in a few minutes after the ignition switch is turned OFF.
- Example of high-load driving
 - Driving for 30 minutes or more at 140 km/h (86 MPH) or more.
 - Driving for 30 minutes or more on a steep slope.
- For vehicles with the 2-batteries, be sure to connect the main battery and the sub battery before turning ON the ignition switch.

NOTE:

If the ignition switch is turned ON with any one of the terminals of main battery and sub battery disconnected, then DTC may be detected.

- After installing the 12V battery, always check "Self Diagnosis Result" of all ECUs and erase DTC.

NOTE:

The removal of 12V battery may cause a DTC detection error.

Handling for Adhesive and Primer

INFOID:000000012794162

- Do not use an adhesive which is past its usable date. Shelf life of this product is limited to six months after the date of manufacture. Carefully adhere to the expiration or manufacture date printed on the box.
- Keep primers and adhesive in a cool, dry place. Ideally, they should be stored in a refrigerator.
- Open the seal of the primer and adhesive just before application. Discard the remainder.
- Before application, be sure to shake the primer container to stir the contents. If any floating material is found, do not use it.
- If any primer or adhesive contacts the skin, wipe it off with gasoline or equivalent and wash the skin with soap.
- When using primer and adhesive, always observe the precautions in the instruction manual.

PREPARATION

< PREPARATION >

PREPARATION

PREPARATION

Special Service Tools

INFOID:000000012794163

The actual shapes of Kent-Moore tools may differ from those of special service tools illustrated here.

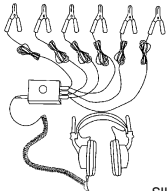
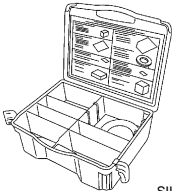
| Tool number (Kent-Moore No.) Tool name | Description |
|--|-----------------------------------|
| <p>(J-39570) Chassis ear</p>  <p style="text-align: center;">SIIA0993E</p> | <p>Locates the noise</p> |
| <p>(J-50397) NISSAN Squeak and Rattle Kit</p>  <p style="text-align: center;">SIIA0994E</p> | <p>Repairs the cause of noise</p> |

Commercial Service Tools

INFOID:000000012794164

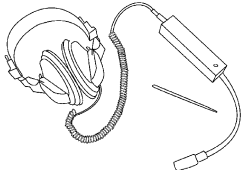
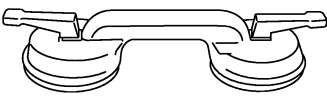
| Tool name | Description |
|--|---|
| <p>Engine ear</p>  <p style="text-align: center;">SIIA0995E</p> | <p>Locates the noise</p> |
| <p>Suction lifter</p>  <p style="text-align: center;">PIIB1805J</p> | <p>Holds the windshield glass, side window glass and back door window glass</p> |

SQUEAK AND RATTLE TROUBLE DIAGNOSES

< SYMPTOM DIAGNOSIS >

SYMPTOM DIAGNOSIS

SQUEAK AND RATTLE TROUBLE DIAGNOSES

Work Flow

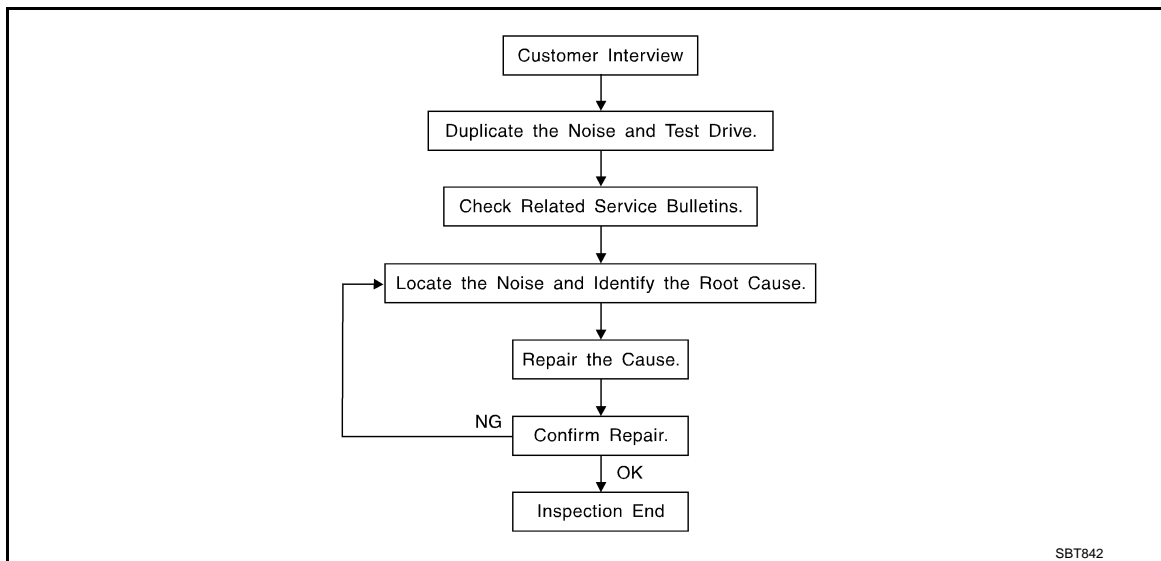

CUSTOMER INTERVIEW

Interview the customer if possible, to determine the conditions that exist when the noise occurs. Use the Diagnostic Worksheet during the interview to document the facts and conditions when the noise occurs and any customer comments. Refer to [GW-9, "Diagnostic Worksheet"](#). This information is necessary to duplicate the conditions that exist when the noise occurs.

- The customer may not be able to provide a detailed description or the location of the noise. Attempt to obtain all the facts and conditions that exist when the noise occurs (or does not occur).
- If there is more than one noise in the vehicle, perform a diagnosis and repair the noise that the customer is concerned about. This can be accomplished by performing a test drive with the customer.
- After identifying the type of noise, isolate the noise in terms of its characteristics. The noise characteristics are provided so that the customer, service adviser, and technician use the same language when describing the noise.
- Squeak – (Like tennis shoes on a clean floor)
Squeak characteristics include the light contact / fast movement / brought on by road conditions / hard surfaces = high-pitched noise / softer surfaces = low-pitched noises / edge to surface = chirping
- Creak – (Like walking on an old wooden floor)
Creak characteristics include firm contact / slow movement/twisting with a rotational movement / pitch dependent on materials / often brought on by activity.
- Rattle – (Like shaking a baby rattle)
Rattle characteristics include fast repeated contact / vibration or similar movement / loose parts/missing clip or fastener / incorrect clearance.
- Knock – (Like a knock on a door)
Knock characteristics include hollow sounds / sometimes repeating / often brought on by driver action.
- Tick – (Like a clock second hand)
Tick characteristics include gentle contacting of light materials / loose components / can be caused by driver action or road conditions.
- Thump – (Heavy, muffled knock noise)
Thump characteristics include softer knock / dull sounds often brought on by activity.
- Buzz – (Like a bumblebee)
Buzz characteristics include high frequency rattle / firm contact.
- Often the degree of acceptable noise level varies depending upon the person. A noise that a technician may judge as acceptable may be very irritating to a customer.
- Weather conditions, especially humidity and temperature, may have a great effect on noise level.

DUPLICATE THE NOISE AND TEST DRIVE

SQUEAK AND RATTLE TROUBLE DIAGNOSES

< SYMPTOM DIAGNOSIS >

If possible, drive the vehicle with the customer until the noise is duplicated. Note any additional information on the Diagnostic Worksheet regarding the conditions or location of the noise. This information can be used to duplicate the same conditions when the repair is reconfirmed.

If the noise can be duplicated easily during the test drive, to help identify the source of the noise, try to duplicate the noise with the vehicle stopped by doing one or all of the following items:

- 1) Close a door.
 - 2) Tap or push/pull around the area where the noise appears to be coming from.
 - 3) Rev the engine.
 - 4) Use a floor jack to recreate vehicle "twist".
 - 5) At idle, apply engine load (electrical load, half-clutch on M/T models, drive position on A/T models).
 - 6) Raise the vehicle on a hoist and hit a tire with a rubber hammer.
- Drive the vehicle and attempt to duplicate the conditions the customer states exist when the noise occurs.
 - If it is difficult to duplicate the noise, drive the vehicle slowly on an undulating or rough road to stress the vehicle body.

CHECK RELATED SERVICE BULLETINS

After verifying the customer concern or symptom, check ASIST for Technical Service Bulletins (TSBs) related to the concern or symptom.

If a TSB relates to the symptom, follow the procedure to repair the noise.

LOCATE THE NOISE AND IDENTIFY THE ROOT CAUSE

1. Narrow down the noise to a general area. To help pinpoint the source of the noise, use a listening tool (Chassis ear: J-39570, engine ear, and mechanics stethoscope).
2. Narrow down the noise to a more specific area and identify the cause of the noise by:
 - Removing the component(s) in the area that is / are suspected to be the cause of the noise.
Do not use too much force when removing clips and fasteners, otherwise clips and fasteners can be broken or lost during the repair, resulting in the creation of new noise.
 - Tapping or pushing/pulling the component(s) that is / are suspected to be the cause of the noise.
Do not tap or push/pull the component(s) with excessive force, otherwise the noise is eliminated only temporarily.
 - Feeling for a vibration by hand by touching the component(s) that is / are suspected to be the cause of the noise.
 - Placing a piece of paper between components that are suspected to be the cause of the noise.
 - Looking for loose components and contact marks.
Refer to [GW-7, "Inspection Procedure"](#).

REPAIR THE CAUSE

- If the cause is a loose component, tighten the component securely.
- If the cause is insufficient clearance between components:
 - Separate components by repositioning or loosening and retightening the components, if possible.
 - Insulate components with a suitable insulator such as urethane pads, foam blocks, felt cloth tape, or urethane tape. A NISSAN Squeak and Rattle Kit (J-50397) is available through the authorized NISSAN Parts Department.

CAUTION:

Never use excessive force as many components are constructed of plastic and may be damaged.

NOTE:

Always check with the Parts Department for the latest parts information.

The following materials are contained in the NISSAN Squeak and Rattle Kit (J-50397). Are listed on inside cover of the kit; and can each be ordered separately as needed.

URETHANE PADS [1.5 mm (0.059 in) thick]

Insulates connectors, harness, etc.

- 76268-9E005: 100 × 135 mm (3.937 × 5.315 in)
- 76884-71L01: 60 × 85 mm (2.362 × 3.346 in)
- 76884-71L02: 15 × 25 mm (0.591 × 0.984 in)

INSULATOR (Foam blocks)

Insulates components from contact. Can be used to fill space behind a panel.

- 73982-9E000: 45 mm (1.772 in) thick, 50 × 50 mm (1.969 × 1.969 in)
- 73982-50Y00: 10 mm (0.394 in) thick, 50 × 50 mm (1.969 × 1.969 in)

INSULATOR (Light foam block)

80845-71L00: 30 mm (1.181 in) thick, 30 × 50 mm (1.181 × 1.969 in)

FELT CLOTHTAPE

SQUEAK AND RATTLE TROUBLE DIAGNOSES

< SYMPTOM DIAGNOSIS >

Used to insulate where movement does not occur. Ideal for instrument panel applications.

- 68370-4B000: 15 × 25 mm (0.591 × 0.984 in) pad
- 68239-13E00: 5 mm (0.197 in) wide tape roll

The following materials, not found in the kit, can also be used to repair squeaks and rattles.

UHMW (TEFLON) TAPE

Insulates where slight movement is present. Ideal for instrument panel applications.

SILICONE GREASE

Used in place of UHMW tape that is visible or does not fit. Only lasts a few months.

SILICONE SPRAY

Used when grease cannot be applied.

DUCT TAPE

Used to eliminate movement.

CONFIRM THE REPAIR

After repair is complete, test drive the vehicle to confirm that the cause of noise is repaired by test driving the vehicle. Operate the vehicle under the same conditions as when the noise originally occurred. Refer to the notes on the Diagnostic Worksheet.

Inspection Procedure

INFOID:000000012794166

Refer to Table of Contents for specific component removal and installation information.

INSTRUMENT PANEL

Most incidents are caused by contact and movement between:

1. The cluster lid A and instrument panel
2. Acrylic lens and combination meter housing
3. Instrument panel to front pillar garnish
4. Instrument panel to windshield
5. Instrument panel mounting pins
6. Wiring harnesses behind the combination meter
7. A/C defroster duct and duct joint

These incidents can usually be located by tapping or moving the components to duplicate the noise or by pressing on the components while driving to stop the noise. Most of these incidents can be repaired by applying felt cloth tape or silicon spray (in hard to reach areas). Urethane pads can be used to insulate wiring harness.

CAUTION:

Never use silicone spray to isolate a squeak or rattle. If the area is saturated with silicone, the recheck of repair becomes impossible.

CENTER CONSOLE

Components to check include:

1. Shifter assembly cover to finisher
2. A/C control unit and cluster lid C
3. Wiring harnesses behind audio and A/C control unit

The instrument panel repair and isolation procedures also apply to the center console.

DOORS

Check the following items:

1. Finisher and inner panel making a slapping noise
2. Inside handle escutcheon connection to door finisher
3. Wiring harnesses tapping
4. Door striker out of alignment causing a popping noise on starts and stops

Tapping, moving the components, or pressing on them while driving to duplicate the conditions can isolate many of these incidents. The areas can usually be insulated with felt cloth tape or insulator foam blocks from the NISSAN Squeak and Rattle Kit (J-50397) to repair the noise.

TRUNK

Trunk noises are often caused by a loose jack or loose items put into the trunk by the customer.

In addition check for the following items:

SQUEAK AND RATTLE TROUBLE DIAGNOSES

< SYMPTOM DIAGNOSIS >

1. Trunk lid dumpers out of adjustment
2. Trunk lid striker out of adjustment
3. Trunk lid torsion bars knocking together
4. A loose license plate or bracket

Most of these incidents can be repaired by adjusting, securing, or insulating the item(s) or component(s) causing the noise.

SUNROOF/HEADLINING

Noises in the sunroof / headlining area can often be traced to one of the following items:

1. Sunroof lid, rail, linkage, or seals making a rattle or light knocking noise
2. Sun visor shaft shaking in the holder
3. Front or rear windshield touching headlining and squeaking

Again, pressing on the components to stop the noise while duplicating the conditions can isolate most of these incidents. Repairs usually consist of insulating with felt cloth tape.

SEATS

When isolating seat noise it is important to note the position the seat is in and the load placed on the seat when the noise occurs. These conditions should be duplicated when verifying and isolating the cause of the noise.

Causes of seat noise include:

1. Headrest rods and holder
2. A squeak between the seat pad cushion and frame
3. The rear seatback lock and bracket

These noises can be isolated by moving or pressing on the suspected components while duplicating the conditions under which the noise occurs. Most of these incidents can be repaired by repositioning the component or applying urethane tape to the contact area.

UNDERHOOD

Some interior noise may be caused by components under the hood or on the engine wall. The noise is then transmitted into the passenger compartment.

Causes of transmitted underhood noise include:

1. Any component mounted to the engine wall
2. Components that pass through the engine wall
3. Engine wall mounts and connectors
4. Loose radiator mounting pins
5. Hood bumpers out of adjustment
6. Hood striker out of adjustment

These noises can be difficult to isolate since they cannot be reached from the interior of the vehicle. The best method is to secure, move, or insulate one component at a time and test drive the vehicle. Also, engine RPM or load can be changed to isolate the noise. Repairs can usually be made by moving, adjusting, securing, or insulating the component causing the noise.

SQUEAK AND RATTLE TROUBLE DIAGNOSES

< SYMPTOM DIAGNOSIS >

Diagnostic Worksheet

INFOID:000000012794167



SQUEAK & RATTLE DIAGNOSTIC WORKSHEET

Dear Infiniti Customer:

We are concerned about your satisfaction with your Infiniti vehicle. Repairing a squeak or rattle sometimes can be very difficult. To help us fix your Infiniti right the first time, please take a moment to note the area of the vehicle where the squeak or rattle occurs and under what conditions. You may be asked to take a test drive with a service consultant or technician to ensure we confirm the noise you are hearing.

I. WHERE DOES THE NOISE COME FROM? (circle the area of the vehicle)

The illustrations are for reference only, and may not reflect the actual configuration of your vehicle.

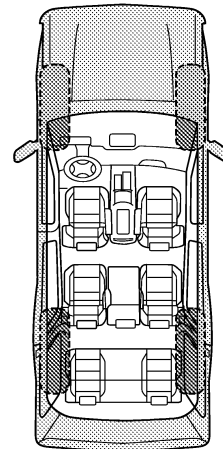
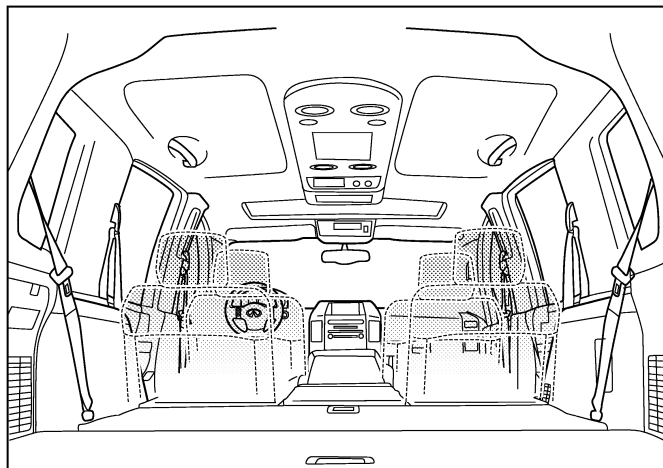
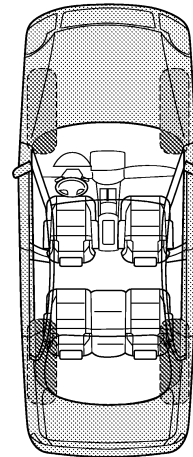
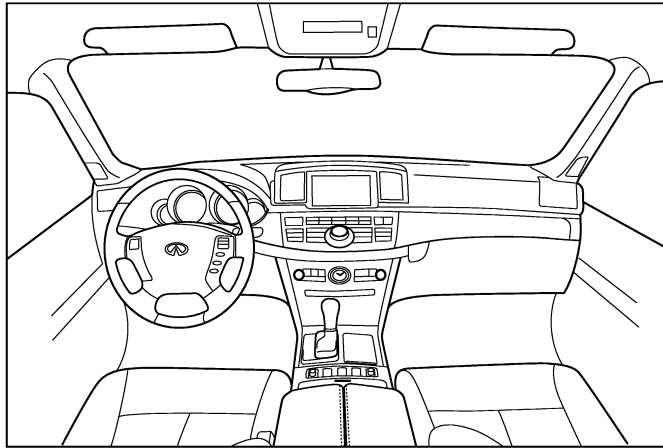

Continue to page 2 of the worksheet and briefly describe the location of the noise or rattle. In addition, please indicate the conditions which are present when the noise occurs.

PIIB8741E

A
B
C
D
E
F
G
H
I
J
GW
L
M
N
O
P

SQUEAK AND RATTLE TROUBLE DIAGNOSES

< SYMPTOM DIAGNOSIS >

SQUEAK & RATTLE DIAGNOSTIC WORKSHEET - page 2

Briefly describe the location where the noise occurs:

II. WHEN DOES IT OCCUR? (please check the boxes that apply)

- | | |
|---|--|
| <input type="checkbox"/> anytime | <input type="checkbox"/> after sitting out in the rain |
| <input type="checkbox"/> 1st time in the morning | <input type="checkbox"/> when it is raining or wet |
| <input type="checkbox"/> only when it is cold outside | <input type="checkbox"/> dry or dusty conditions |
| <input type="checkbox"/> only when it is hot outside | <input type="checkbox"/> other: |

III. WHEN DRIVING:

- through driveways
- over rough roads
- over speed bumps
- only about ____ mph
- on acceleration
- coming to a stop
- on turns: left, right or either (circle)
- with passengers or cargo
- other: _____
- after driving ____ miles or ____ minutes

IV. WHAT TYPE OF NOISE

- squeak (like tennis shoes on a clean floor)
- creak (like walking on an old wooden floor)
- rattle (like shaking a baby rattle)
- knock (like a knock at the door)
- tick (like a clock second hand)
- thump (heavy, muffled knock noise)
- buzz (like a bumble bee)

TO BE COMPLETED BY DEALERSHIP PERSONNEL

Test Drive Notes:

| | YES | NO | Initials of person performing |
|--|--------------------------|--------------------------|-------------------------------|
| Vehicle test driven with customer | <input type="checkbox"/> | <input type="checkbox"/> | _____ |
| - Noise verified on test drive | <input type="checkbox"/> | <input type="checkbox"/> | _____ |
| - Noise source located and repaired | <input type="checkbox"/> | <input type="checkbox"/> | _____ |
| - Follow up test drive performed to confirm repair | <input type="checkbox"/> | <input type="checkbox"/> | _____ |

VIN: _____ Customer Name: _____
W.O.# _____ Date: _____

This form must be attached to Work Order

PIIB8742E

WINDSHIELD GLASS

< REMOVAL AND INSTALLATION >

REMOVAL AND INSTALLATION

WINDSHIELD GLASS

Exploded View

INFOID:000000012794168

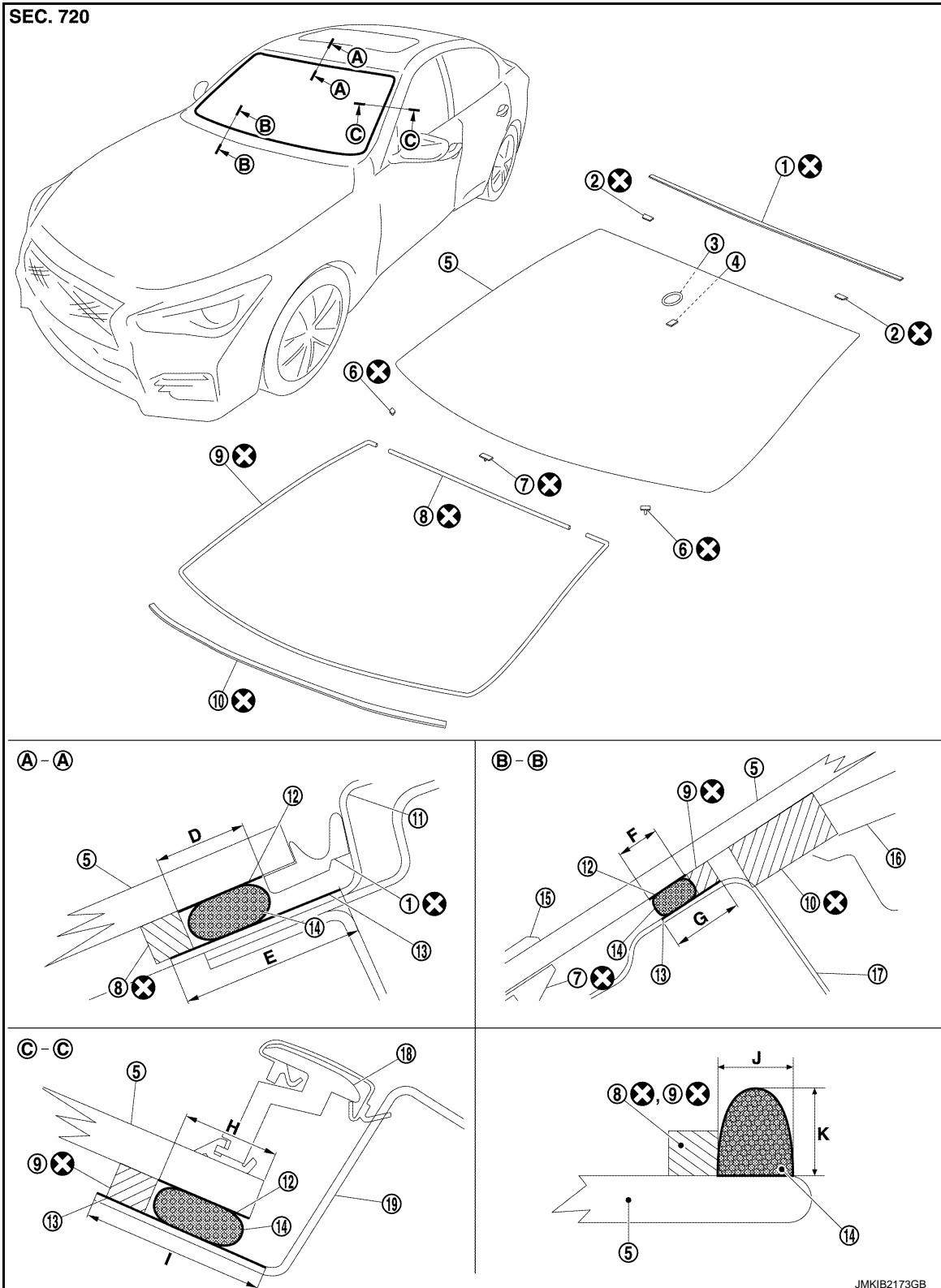

A
B
C
D
E
F
G
H
I
J
GW
L
M
N
O
P

WINDSHIELD GLASS

< REMOVAL AND INSTALLATION >

- | | | |
|--|---------------------------------|--------------------------------------|
| ① Windshield glass upper molding | ② Windshield glass upper spacer | ③ Rain sensor bracket* |
| ④ Inside mirror base | ⑤ Windshield glass | ⑥ Windshield glass lower side spacer |
| ⑦ Windshield glass lower center spacer | ⑧ Dam sealant rubber upper | ⑨ Dam sealant rubber lower |
| ⑩ Windshield glass insulator | ⑪ Roof panel | ⑫ Glass primer |
| ⑬ Body primer | ⑭ Adhesive | ⑮ Cowl top cover |
| ⑯ Front speaker grille | ⑰ Dash upper panel | ⑱ Roof side molding |
| ⑲ Body side outer panel | | |
- ⊗ : Always replace after every disassembly.

*: With rain sensor

Unit: mm (in)

| Portion | | Primer range | Adhesive range | | |
|--|-------|--------------|-----------------|----------------|-----------------|
| | | | J | K | |
| Windshield glass – Roof panel | Ⓐ – Ⓐ | D | 12.0 (0.472) | 7.0 (0.276) | 12.0 (0.472) |
| | | E | 20.0 (0.787) | — | — |
| Windshield glass – Dash upper panel | Ⓑ – Ⓑ | F | 10.5 (0.413) | 7.0 (0.276) | 12.0 (0.472) |
| | | G | 17.0 (0.669) | — | — |
| Windshield glass – Body side outer panel | Ⓒ – Ⓒ | H | 11.0 (0.433) | 7.0 (0.276) | 12.0 (0.472) |
| | | I | 19.0 (0.748) | — | — |

Removal and Installation

INFOID:000000012794169

REMOVAL

Replacement Windshield Glass

CAUTION:

Never damage the windshield glass and body panel.

- Remove all assist grips.
Disengage assist grip cap fixing pawl using a remover tool (A), and then slide assist grip cap and remove it according to numerical order 1→2 indicated by arrows as shown in the figure.

△ : Pawl

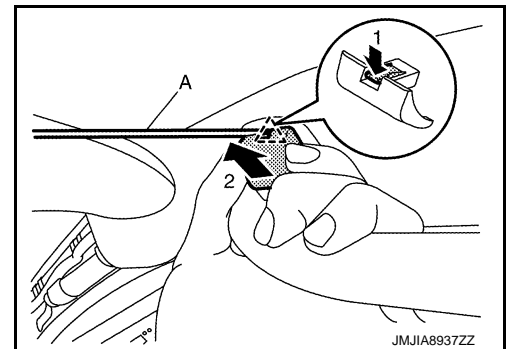

- Remove center pillar upper garnish (LH and RH). Refer to [INT-33. "CENTER PILLAR UPPER GARNISH : Removal and Installation"](#).
- Remove front pillar garnish (LH and RH). Refer to [INT-25. "FRONT PILLAR GARNISH : Removal and Installation"](#).

WINDSHIELD GLASS

< REMOVAL AND INSTALLATION >

4. Disengage rain sensor cover fixing pawls, and then remove rain sensor cover. (With rain sensor)

 : Pawl

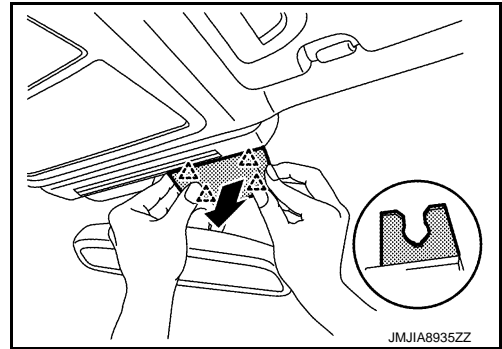

5. Remove inside mirror harness cover. (Without rain sensor)
- a. Slide part ① of inside mirror harness cover ① in the direction of the arrow in the figure.

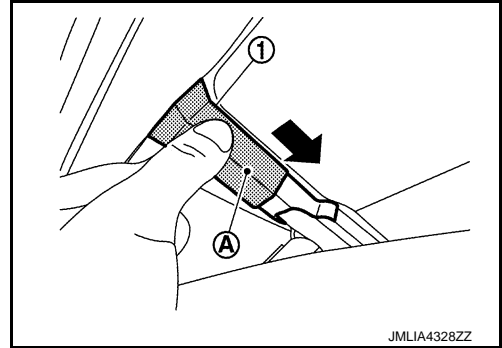

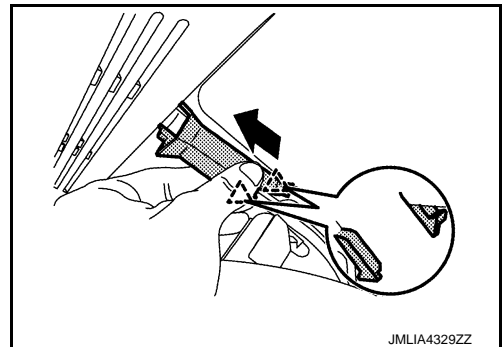

- b. Disengage inside mirror harness cover fixing pawls, and then remove inside mirror harness cover.

 : Pawl



6. Disengage inside mirror cover fixing pawls and metal clips, and then remove inside mirror cover.

 : Pawl
 : Metal clip

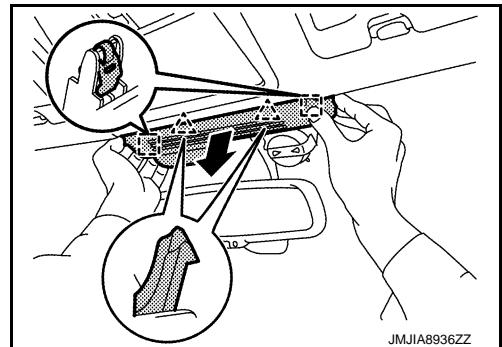

7. Remove inside mirror assembly. Refer to the following.
- With automatic drive positioner: Refer to [MIR-47, "Removal and Installation"](#).
 - Without automatic drive positioner: Refer to [MIR-73, "Removal and Installation"](#).
8. Remove map lamp assembly. Refer to [INL-74, "MAP LAMP : Removal and Installation"](#).
9. Remove sun visor assembly (LH and RH).

A
B
C
D
E
F
G
H
I
J
GW
L
M
N
O
P

WINDSHIELD GLASS

< REMOVAL AND INSTALLATION >

- a. Disengage sun visor cover fixing pawls using a remover tool (A), and then remove sun visor cover (LH and RH).

 : Pawl

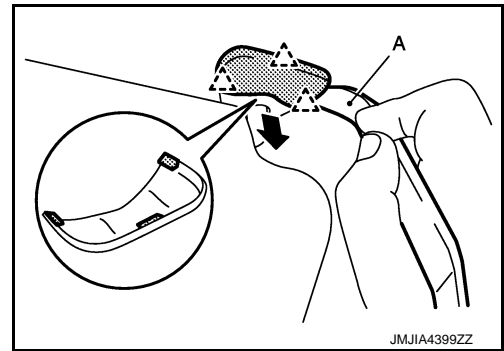

- b. Remove sun visor assembly fixing screws, and then disconnect vanity mirror lamp harness connector.
c. Remove sun visor assembly (LH and RH).

10. Remove sun visor holder (LH and RH) using a remover tool according to numerical order 1→2 indicated by arrows as shown in the figure.

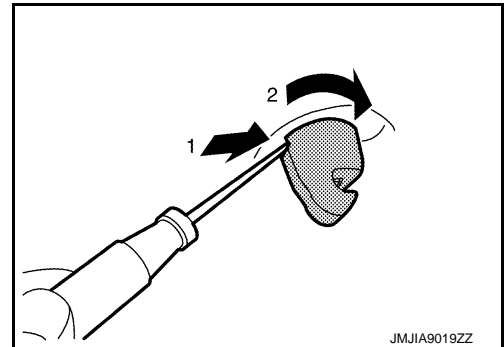

11. Peel off dual lock fasteners (A) between headlining assembly and roof panel. (With sunroof)

CAUTION:

Never bend headlining when removing.

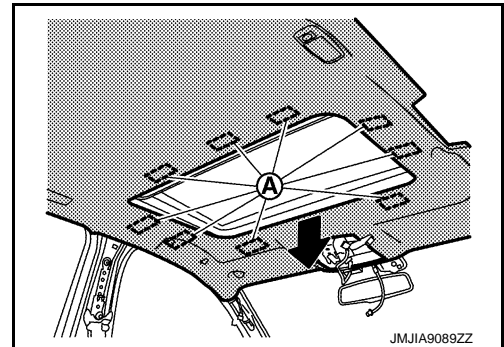

12. Remove front portion of headlining as shown in the figure.

CAUTION:

To prevent damage of the headlining assembly, hold the headlining assembly using a rope or tape before removal operation.

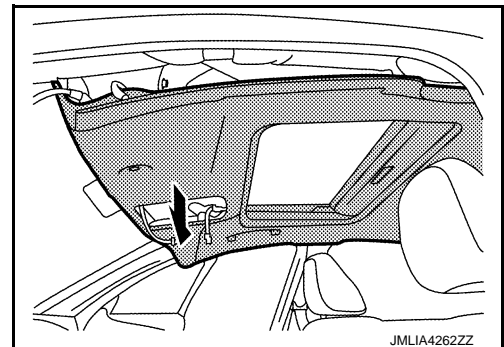

13. Remove roof side molding (LH and RH). Refer to [EXT-39. "Removal and Installation"](#).

14. Remove cowl top cover. Refer to [EXT-27. "Removal and Installation"](#).

WINDSHIELD GLASS

< REMOVAL AND INSTALLATION >

15. Apply protective tape (A) on body panel around windshield glass to protect painted surface from damage.

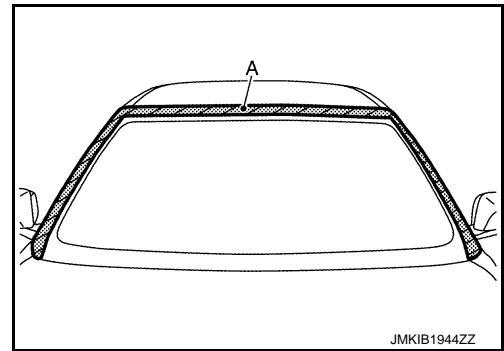

16. Remove windshield glass upper molding.
CAUTION:
Remove windshield glass upper molding left on vehicle using a pliers etc.

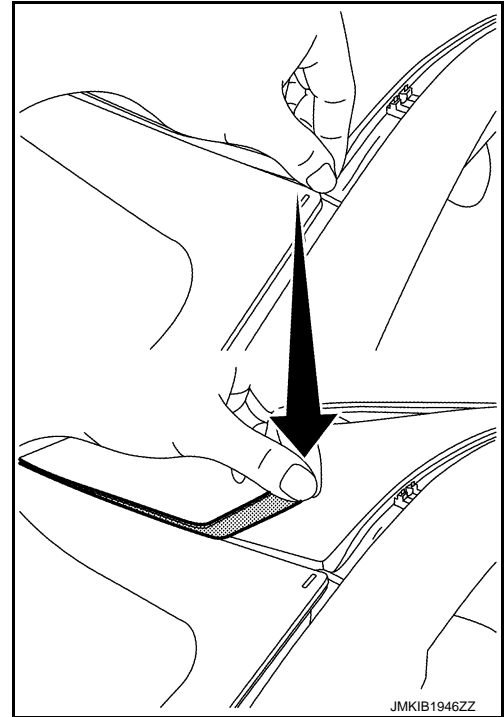

17. Apply protective standish cover (A) on instrument panel to protect it from damage.

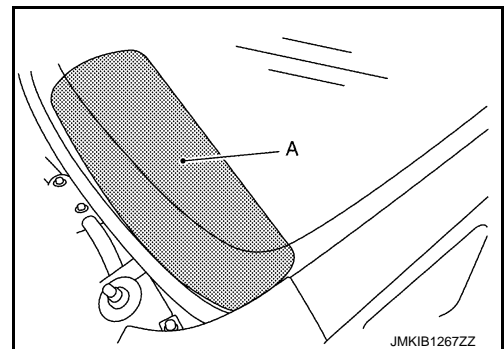

18. Cut the adhesive using a piano wire.

A
B
C
D
E
F
G
H
I
J
GW
L
M
N
O
P

WINDSHIELD GLASS

< REMOVAL AND INSTALLATION >

- a. Pass the piano wire (B) from passenger room to bonded area of glass using a wire pierce (A).

CAUTION:

- Never press piano wire excessively against edge of glass.
- For corner area, never insert piano wire into the mating surfaces of glass.
- Never damage harness around glass.

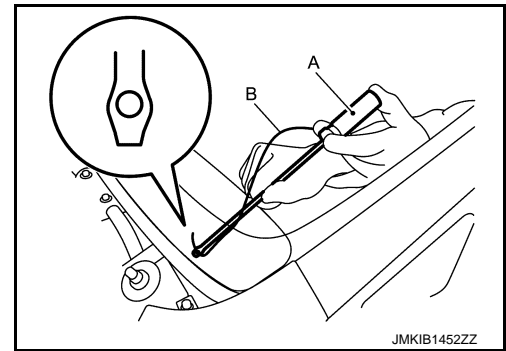

- b. Tie both ends of the piano wire (B) to the wire grip (A), etc.

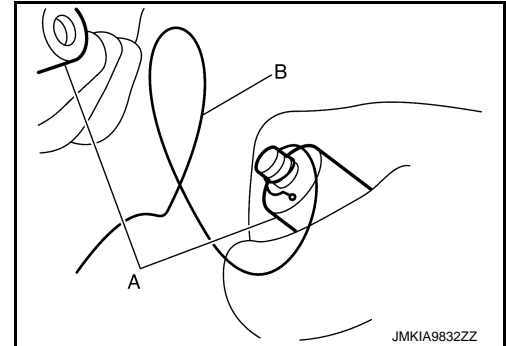

- c. With 2 persons, one holding the piano wire inside the vehicle along with the glass and the other holding it outside the vehicle along with the gap between the body and glass, pull one grip to cut off the adhesive.

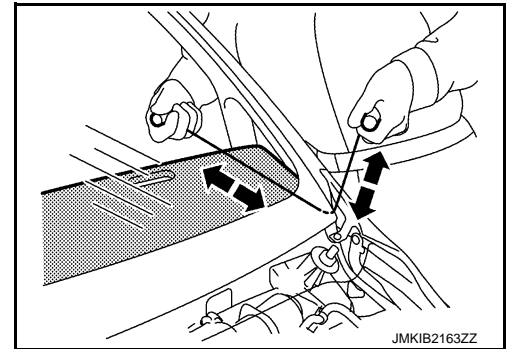

19. Using a windshield cutter (A) into the bonded area. Cut the adhesive by pulling the knife, keeping the tip parallel to the edge of glass.

NOTE:

Apply soapy water around the bonded area on the body for smooth movement of windshield cutter.

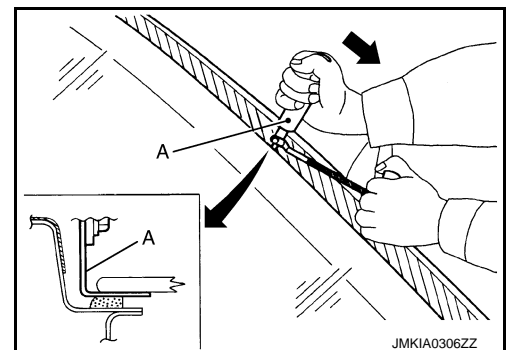

20. Use rubber suction cups or suction lifter (A), etc. to remove windshield glass from the vehicle.

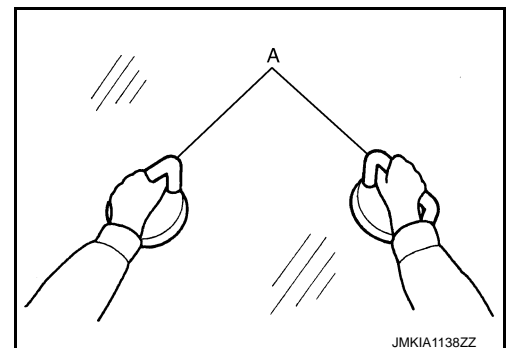

WINDSHIELD GLASS

< REMOVAL AND INSTALLATION >

Reuse Windshield Glass

CAUTION:

- Never use a windshield cutter if the windshield glass is reused. (It may scratch the glass surface)
- Never damage the windshield glass and body panel.

1. Remove all assist grips.
Disengage assist grip cap fixing pawl using a remover tool (A), and then slide assist grip cap and remove it according to numerical order 1→2 indicated by arrows as shown in the figure.

 : Pawl

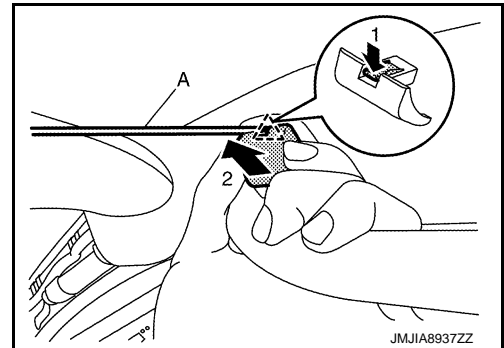

2. Remove center pillar upper garnish (LH and RH). Refer to [INT-33, "CENTER PILLAR UPPER GARNISH : Removal and Installation"](#).
3. Remove front pillar garnish (LH and RH). Refer to [INT-25, "FRONT PILLAR GARNISH : Removal and Installation"](#).
4. Disengage rain sensor cover fixing pawls, and then remove rain sensor cover. (With rain sensor)

 : Pawl

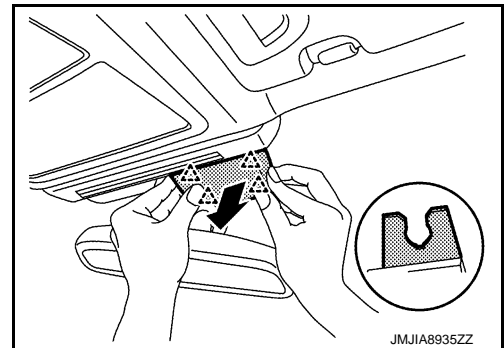

5. Remove inside mirror harness cover. (Without rain sensor)
 - a. Slide part (A) of inside mirror harness cover (1) in the direction of the arrow in the figure.

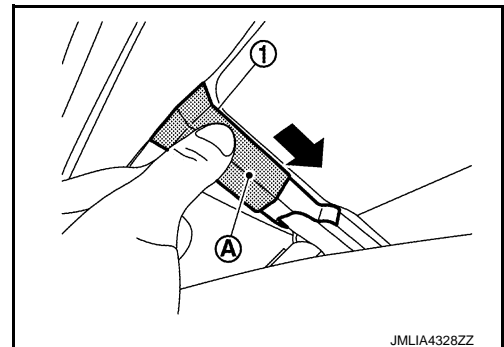

- b. Disengage inside mirror harness cover fixing pawls, and then remove inside mirror harness cover.

 : Pawl

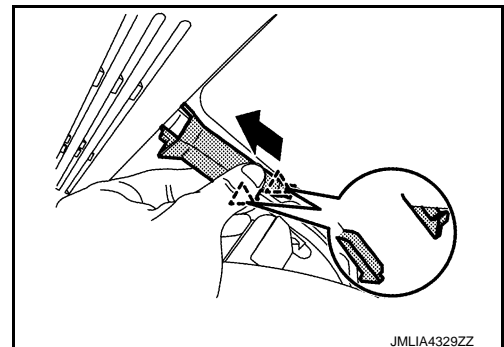

A
B
C
D
E
F
G
H
I
J
GW
L
M
N
O
P

WINDSHIELD GLASS

< REMOVAL AND INSTALLATION >

6. Disengage inside mirror cover fixing pawls and metal clips, and then remove inside mirror cover.

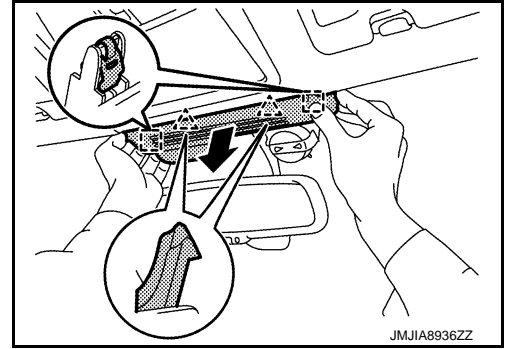
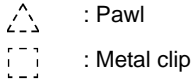

7. Remove inside mirror assembly. Refer to the following.
- With automatic drive positioner: Refer to [MIR-47, "Removal and Installation"](#).
 - Without automatic drive positioner: Refer to [MIR-73, "Removal and Installation"](#).
8. Remove map lamp assembly. Refer to [INL-74, "MAP LAMP : Removal and Installation"](#).
9. Remove sun visor assembly (LH and RH).
- a. Disengage sun visor cover fixing pawls using a remover tool (A), and then remove sun visor cover (LH and RH).

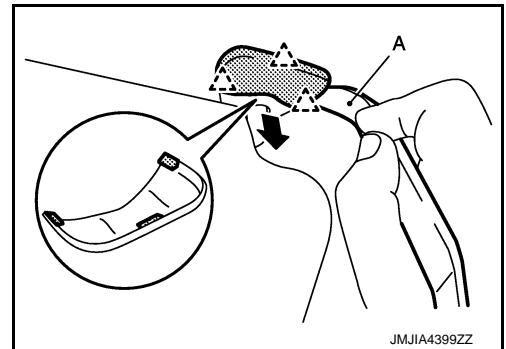
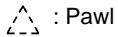

- b. Remove sun visor assembly fixing screws, and then disconnect vanity mirror lamp harness connector.
- c. Remove sun visor assembly (LH and RH).
10. Remove sun visor holder (LH and RH) using a remover tool according to numerical order 1→2 indicated by arrows as shown in the figure.

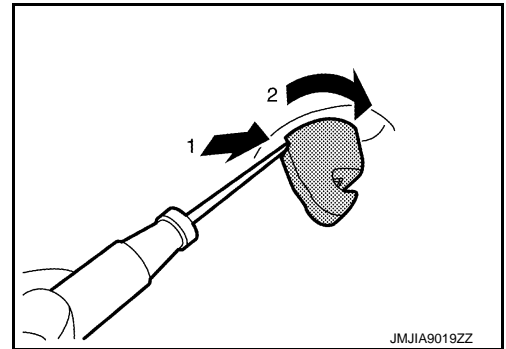

11. Peel off dual lock fasteners (A) between headlining assembly and roof panel. (With sunroof)

CAUTION:
Never bend headlining when removing.

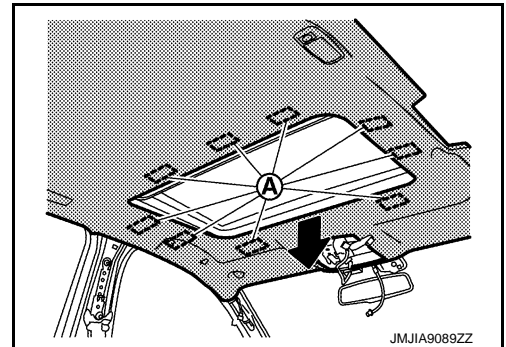

WINDSHIELD GLASS

< REMOVAL AND INSTALLATION >

12. Remove front portion of headlining as shown in the figure.

CAUTION:

To prevent damage of the headlining assembly, hold the headlining assembly using a rope or tape before removal operation.

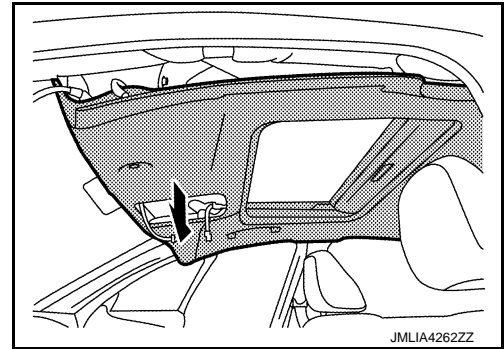

13. Remove roof side molding (LH and RH). Refer to [EXT-39, "Removal and Installation"](#).

14. Remove cowl top cover. Refer to [EXT-27, "Removal and Installation"](#).

15. Apply protective tape (A) on body panel around windshield glass to protect painted surface from damage.

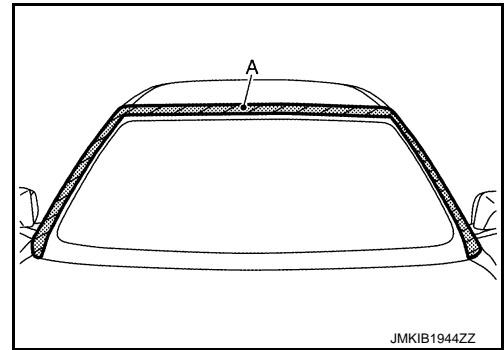

16. Paint matching marks on the windshield glass and body panel, positioning during installation can be easily performed.

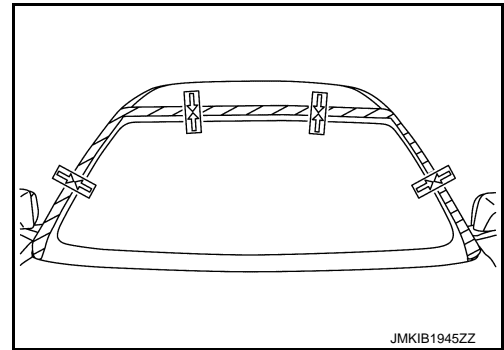

A
B
C
D
E
F
G
H
I
J
GW
L
M
N
O
P

WINDSHIELD GLASS

< REMOVAL AND INSTALLATION >

17. Remove windshield glass upper molding.

CAUTION:

Remove windshield glass upper molding left on vehicle using a pliers etc.

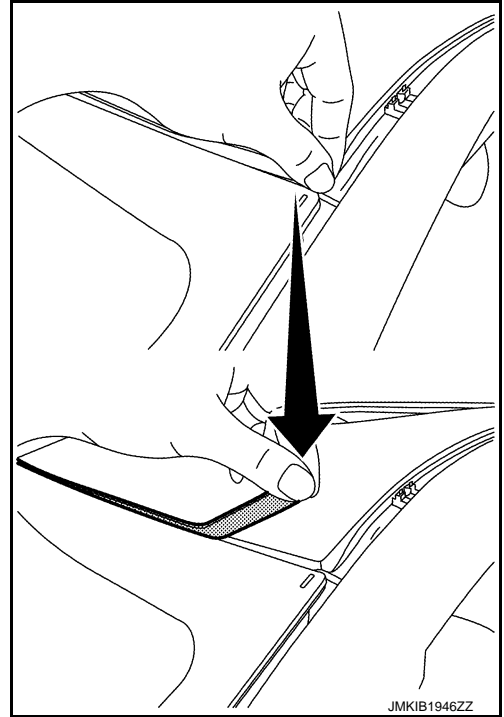

18. Apply protective standish cover (A) on instrument panel to protect it from damage.

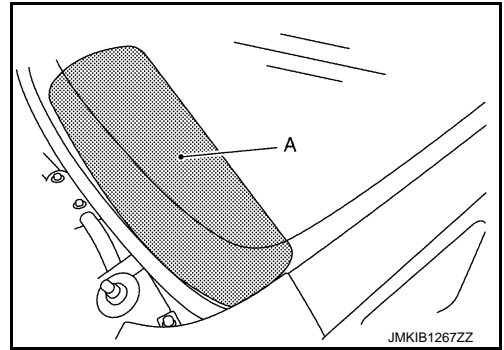

19. Cut the adhesive using a piano wire.

a. Pass the piano wire (B) from passenger room to bonded area of glass using a wire pierce (A).

CAUTION:

- Never press piano wire excessively against edge of glass.
- For corner area, never insert piano wire into the mating surfaces of glass.
- Never damage harness around glass.

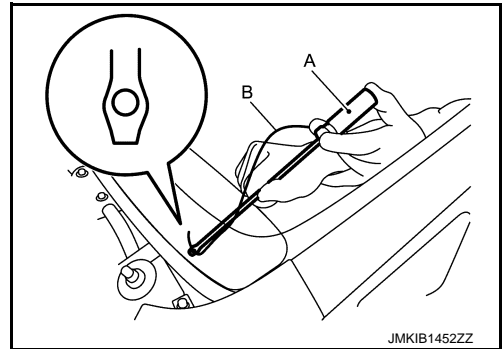

WINDSHIELD GLASS

< REMOVAL AND INSTALLATION >

b. Tie both ends of the piano wire (B) to the wire grip (A), etc.

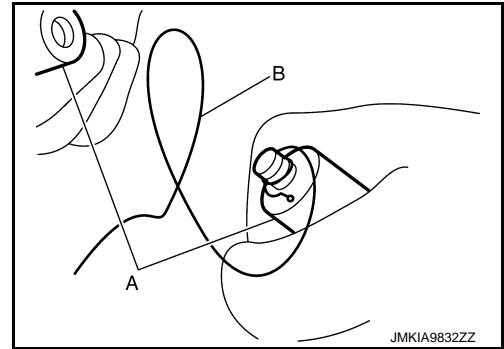

c. With 2 persons, one holding the piano wire inside the vehicle along with the glass and the other holding it outside the vehicle along with the gap between the body and glass, pull one grip to cut off the adhesive.

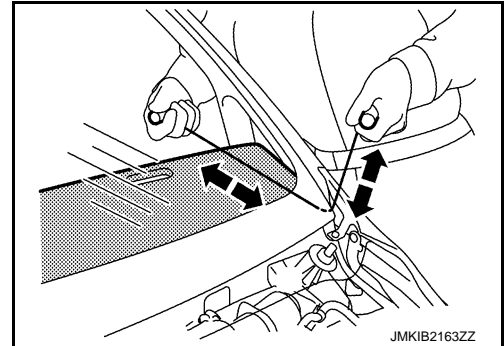

20. Use suction lifter (A) or rubber suction cups, etc. to remove windshield glass from the vehicle.

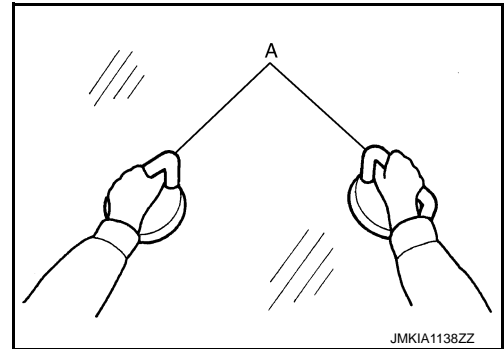

21. Put the marking tape (A) around the windshield glass upper spacers ①, windshield glass lower side spacers and windshield glass lower center spacer remove it from the windshield glass ②.

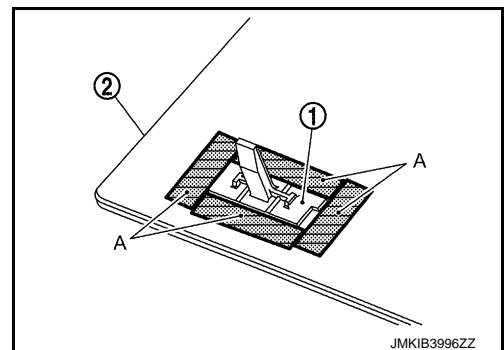

INSTALLATION

Replacement Windshield Glass

A
B
C
D
E
F
G
H
I
J
GW
L
M
N
O
P

WINDSHIELD GLASS

< REMOVAL AND INSTALLATION >

1. Remove remaining adhesive and sealant using a scraper on the body side to approximately a depth that is 2 mm (0.079 in) thickness (A) so that entire contour becomes smooth.

CAUTION:

If the bonded area on the body is scratched, repair it using a 2 liquid type urethane paint. Never use lacquer type paint.

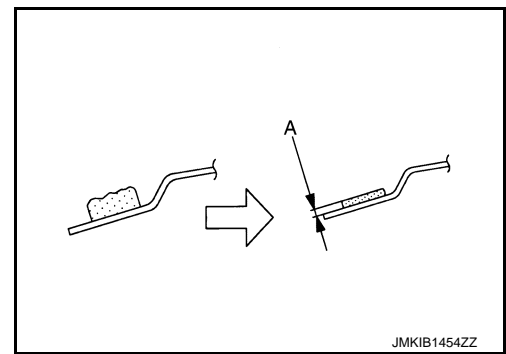

2. Mount the glass onto the vehicle and paint matching marks on the body and glass when installing new glass. Then remove the glass again.
3. Use suction lifter (A) or rubber suction cups to set glass ① on glass stand (B).

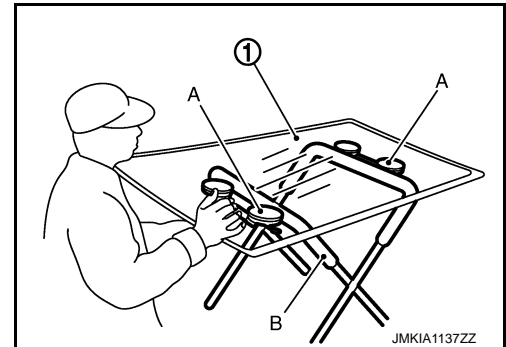

4. Clean the bonded area on glass and body side using a white gasoline or degreasing agent.
5. Install new windshield glass insulator, new spacers and new windshield glass upper molding to windshield glass.
6. When installing new glass ②, apply the dam sealant rubber ① from the edge of the glass so as to hide the black print.

CAUTION:

Start to apply the dam sealant rubber at the outline mark of black print. Apply it so as to only place it without pulling. Stop applying at another outline mark of black print.

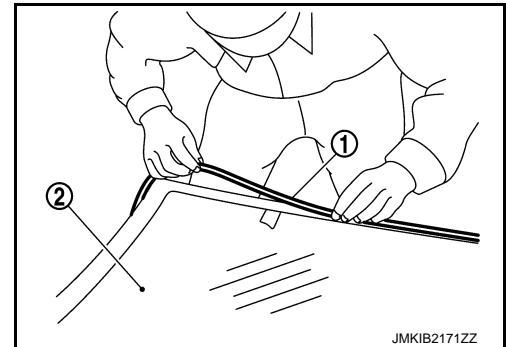

7. Apply primer for glass along the entire circumference of glass. Use the sealing kit for glass application and the special holder for cartridge or similar tools.

CAUTION:

There are 2 types of primer. Never confuse the application methods.

- Primer for painted surfaces
- Primer for glass
- Apply primer for glass and adhesive by following the black print marks on windshield glass.

NOTE:

The essential function of primers is to strengthen adhesion between the glass and the painted surface.

8. Apply primer for the painted surface to the body side bonding surface.

CAUTION:

- If the body side bonding surface is repaired with 2 liquid type urethane paint, always apply the primer after drying the paint.
- If primer for painted surfaces adheres to a painted surface other than the bonding area, or if it overflows, quickly remove it with white gasoline or degreasing agent.
- Always use a Standish cover (stainless plate) to prevent primer for painted surfaces from adhering to the instrument panel assembly.

WINDSHIELD GLASS

< REMOVAL AND INSTALLATION >

9. Use sealant gun (A), affix the dam sealant rubber ① and apply adhesive ② along the edge of the glass within the time period indicated in the service manual after applying primer.

NOTE:

Open adhesive by cutting off the nozzle tip and set it in a sealant gun.

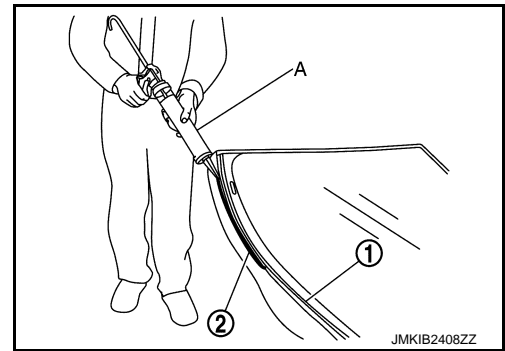

10. Use suction lifter (A) or rubber suction cups that are installed in advance, align the matching marks between the holder and roof panel hole and between the body and windshield glass ① to install them on the vehicle.

CAUTION:

2 workers are required when installing the glass.

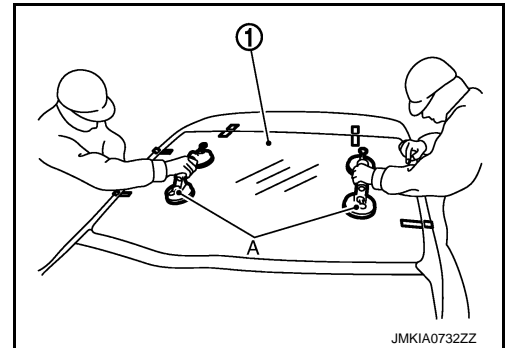

11. Press entire surface of glass lightly to fit it completely.
12. Correct any adhesive overflow or shortage using a spatula to make the surface smooth.

CAUTION:

- Always install the windshield molding before the adhesive hardens.
- After installing glass, keep the front door glass open until the adhesive is completely cured.
- Never drive the vehicle before the adhesive is completely cured.

NOTE:

Lightly affix the center of molding. Affix the whole length while checking the length on the left and right.

13. Remove protective tape.
14. Install the removed parts.

CAUTION:

- Be sure to perform "WRITE CONFIGURATION" when replacing inside mirror assembly (high beam assist control module). Or not doing so, high beam assist control function does not operate normally. Refer to [EXL-131, "Description"](#).
- Check the mating area with surrounding parts. Adjust if necessary.
- Adjust the front wiper arms stop position. Refer to [WW-56, "WIPER ARM : Adjustment"](#).
- After installation windshield glass, perform the inspection. Refer to [GW-25, "Inspection"](#).

Reuse Windshield Glass

1. Remove remaining adhesive and sealant using a scraper on the body side to approximately a depth that is 2 mm (0.079 in) thickness (A) so that entire contour becomes smooth.

CAUTION:

If the bonded area on the body is scratched, repair it using a 2 liquid type urethane paint. Never use lacquer type paint.

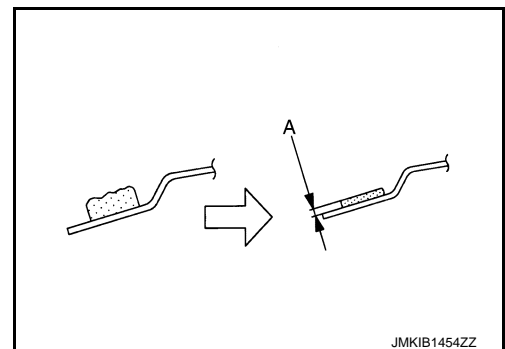

A
B
C
D
E
F
G
H
I
J
GW
L
M
N
O
P

WINDSHIELD GLASS

< REMOVAL AND INSTALLATION >

- Remove remaining adhesive ① and sealant using a cutter-knife (A) smooth out windshield glass surface ②.

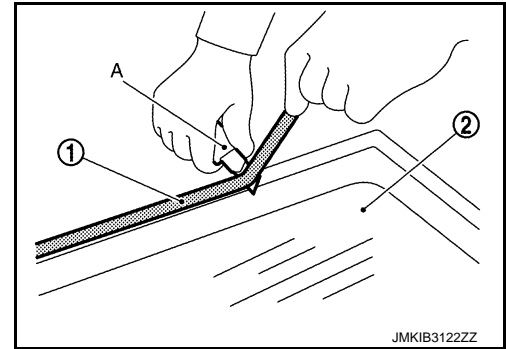

- Remove all windshield glass spacer.
- Use suction lifter (A) or rubber suction cups to set glass ① on glass stand (B).

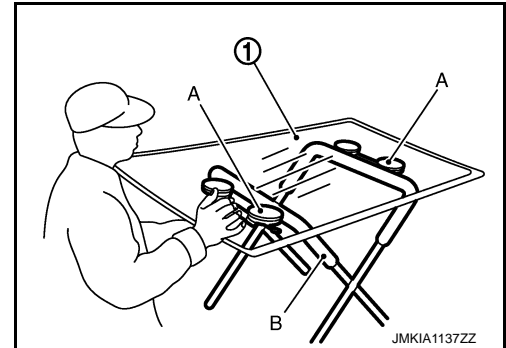

- Clean the bonded area on glass and body side using a white gasoline or degreasing agent.
- Install new windshield glass insulator, new spacers and new windshield glass upper molding to windshield glass.
- When installing windshield glass ②, apply the dam sealant rubber ① from the edge of the glass so as to hide the black print.

CAUTION:

Start to apply the dam sealant rubber at the outline mark of black print. Apply it so as to only place it without pulling. Stop applying at another outline mark of black print.

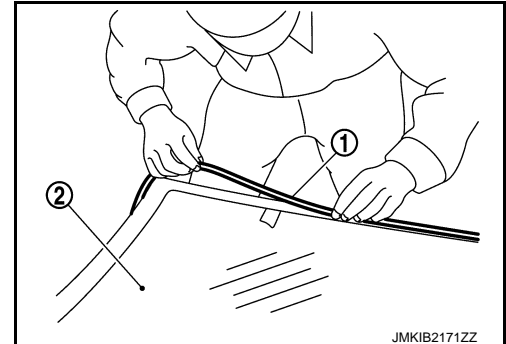

- Apply primer for glass along the entire circumference of glass. Use the sealing kit for glass application and the special holder for cartridge or similar tools.

CAUTION:

There are 2 types of primer. Never confuse the application methods.

- Primer for painted surfaces
- Primer for glass
- Apply primer for glass and adhesive by following the black print marks on windshield glass.

NOTE:

The essential function of primers is to strengthen adhesion between the glass and the painted surface.

- Apply primer for the painted surface to the body side bonding surface.

CAUTION:

- If the body side bonding surface is repaired with 2 liquid type urethane paint, always apply the primer after drying the paint.
- If primer for painted surfaces adheres to a painted surface other than the bonding area, or if it overflows, quickly remove it with white gasoline or degreasing agent.
- Always use a Standish cover (stainless plate) to prevent primer for painted surfaces from adhering to the instrument panel assembly.

WINDSHIELD GLASS

< REMOVAL AND INSTALLATION >

10. Use sealant gun (A), affix the dam sealant rubber ① and apply adhesive ② along the edge of the glass within the time period indicated in the service manual after applying primer.

NOTE:

Open adhesive by cutting off the nozzle tip and set it in a sealant gun.

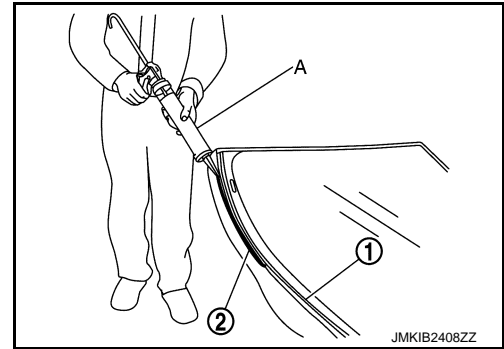

11. Use suction lifter (A) or rubber suction cups that are installed in advance, align the matching marks between the holder and roof panel hole and between the body and windshield glass ① to install them on the vehicle.

CAUTION:

2 workers are required when installing the windshield glass.

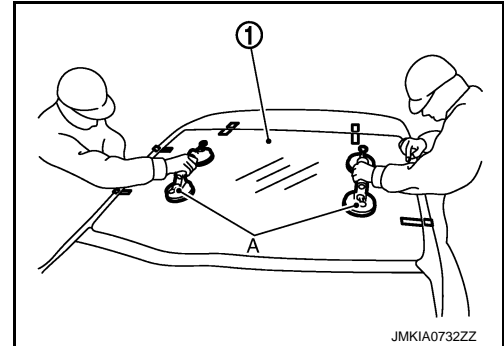

12. Press entire surface of glass lightly to fit it completely.

13. Correct any adhesive overflow or shortage using a spatula to make the surface smooth.

CAUTION:

- Always install the windshield glass upper molding before the adhesive hardens.
- After installing glass, keep the front door glass open until the adhesive is completely cured.
- Never drive the vehicle before the adhesive is completely cured.

NOTE:

Lightly affix the center of molding. Affix the whole length while checking the length on the left and right.

14. Remove protective tape.

15. Install the removed parts.

CAUTION:

- Be sure to perform "WRITE CONFIGURATION" when replacing inside mirror assembly (high beam assist control module). Or not doing so, high beam assist control function does not operate normally. Refer to [EXL-131, "Description"](#).
- Check the mating area with surrounding parts. Adjust if necessary.
- Adjust the front wiper arms stop position. Refer to [WW-56, "WIPER ARM : Adjustment"](#).
- After installation windshield glass, perform the inspection. Refer to [GW-25, "Inspection"](#).

Inspection

INFOID:000000012794170

WATER LEAKAGE INSPECTION

CAUTION:

- Dry adhesive according to the specification of adhesive kit, do the leaking check when adhesive is stiffen.
- If leakage was found, start over from the beginning as windshield glass removal, install and leaking check.

A
B
C
D
E
F
G
H
I
J
L
M
N
O
P

GW

REAR WINDOW GLASS

< REMOVAL AND INSTALLATION >

REAR WINDOW GLASS

Exploded View

INFOID:000000012794171

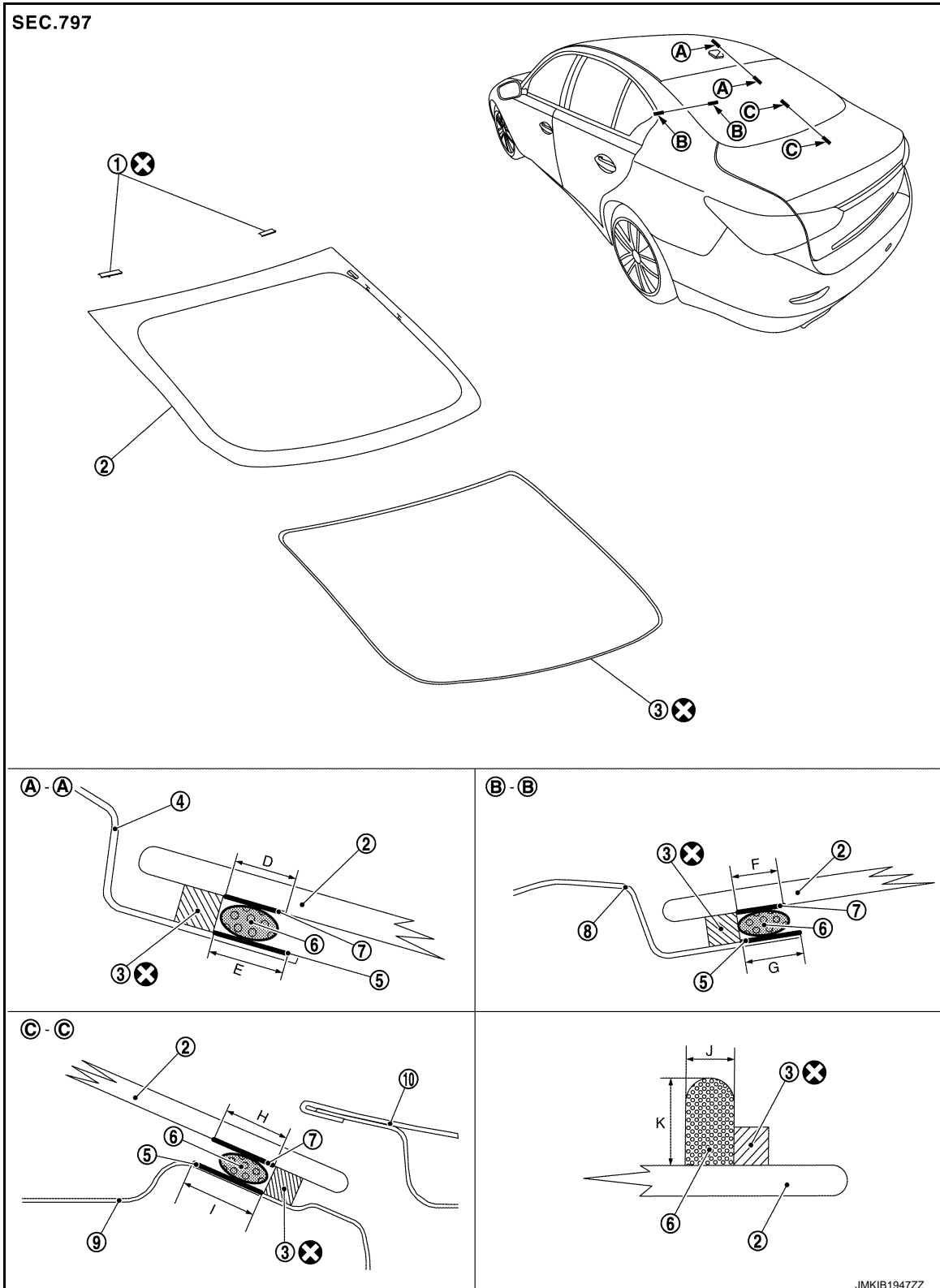

JMKIB1947ZZ

① Rear window glass spacer

② Rear window glass

③ Dam sealant rubber

④ Roof panel

⑤ Body primer

⑥ Adhesive

REAR WINDOW GLASS

< REMOVAL AND INSTALLATION >

- ⑦ Glass primer
- ⑧ Body side outer panel
- ⑨ Waist rear
- ⑩ Trunk lid
- ⊗ : Always replace after every disassembly.

Unit: mm (in)

| Portion | | Primer range | Adhesive range | | |
|---|-------|--------------|--------------------------------|----------------|-----------------|
| | | | J | K | |
| Rear window glass – Roof panel | Ⓐ – Ⓐ | D | 8.0 (0.315) | 7.0 (0.276) | 12.0 (0.472) |
| | | E | 10.0 – 15.0 (0.394 – 0.591) | — | — |
| Rear window glass – Body side outer panel | Ⓑ – Ⓑ | F | 8.0 (0.315) | 7.0 (0.276) | 12.0 (0.472) |
| | | G | 10.0 – 15.0 (0.394 – 0.591) | — | — |
| Rear window glass – Waist rear | Ⓒ – Ⓒ | H | 8.0 (0.315) | 7.0 (0.276) | 12.0 (0.472) |
| | | I | 10.0 – 15.0 (0.394 – 0.591) | — | — |

Removal and Installation

INFOID:0000000012794172

REMOVAL

Replacement Rear Window Glass

CAUTION:

Never damage the rear window glass and body panel.

- Remove all assist grips.
Disengage assist grip cap fixing pawl using a remover tool (A), and then slide assist grip cap and remove it according to numerical order 1→2 indicated by arrows as shown in the figure.

 : Pawl

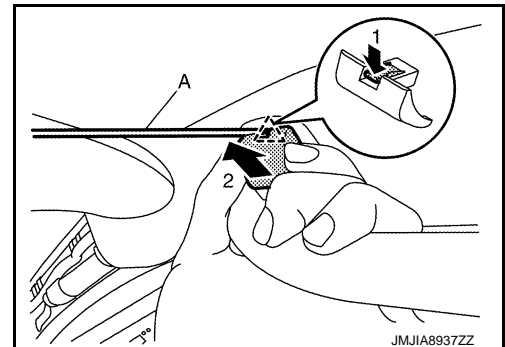

- Remove center pillar upper garnish (LH and RH). Refer to [INT-33, "CENTER PILLAR UPPER GARNISH: Removal and Installation"](#).
- Remove rear parcel shelf finisher. Refer to [INT-37, "Removal and Installation"](#).
- Disconnect rear window defogger connectors LH side Ⓐ and RH side Ⓑ.

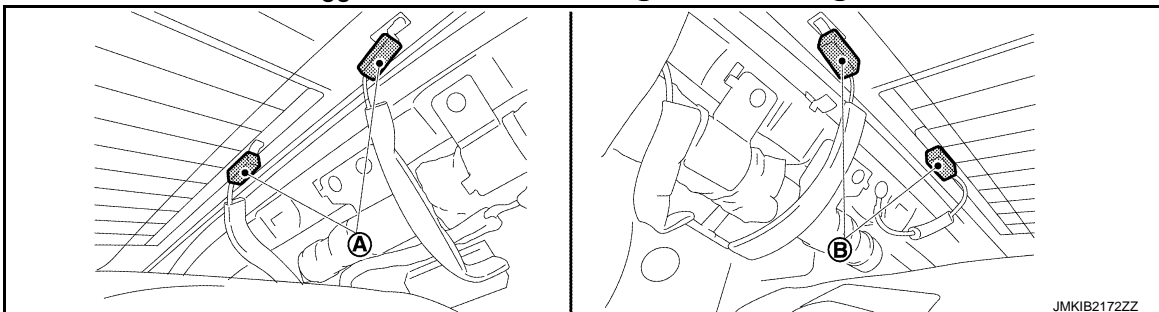

REAR WINDOW GLASS

< REMOVAL AND INSTALLATION >

5. Disengage fixing clips of headlining assembly rear end, and then pull down headlining assembly rear end.

CAUTION:

- 2 workers are required for removal in order to prevent damage.
- Never bend headlining when removing.

 : Clip

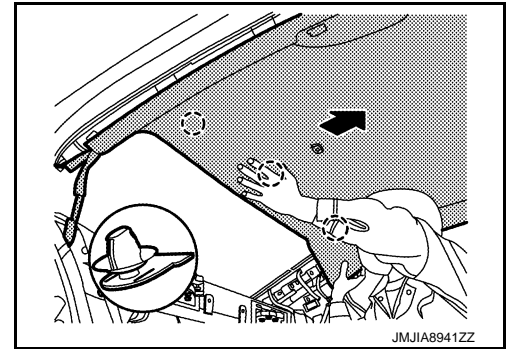

6. Apply protective tape (A) on body panel around rear window glass to protect painted surface from damage.

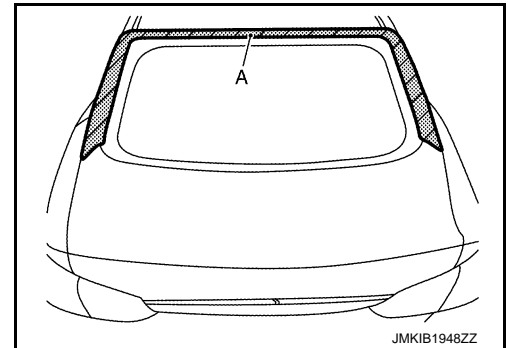

7. Cut the adhesive using a piano wire.

- a. Pass the piano wire from passenger room to bonded area of glass using a wire pierce.

CAUTION:

- Never press piano wire excessively against edge of rear window glass.
- For corner area, never insert piano wire into the mating surfaces of rear window glass.
- Never damage harness around rear window glass.

- b. Tie both ends of the piano wire (B) to wire grip (A), etc.

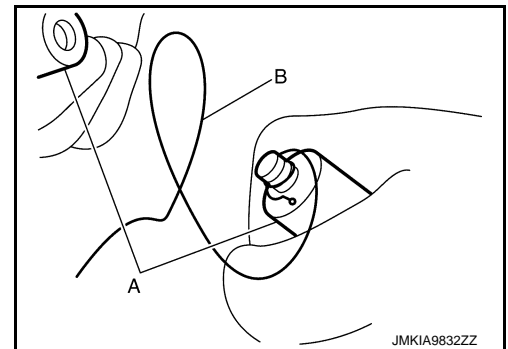

8. Using a windshield cutter (A) into the bonded area. Cut the adhesive by pulling the knife, keeping the tip parallel to the edge of glass.

NOTE:

Apply soapy water around the bonded area on the body for smooth movement of windshield cutter.

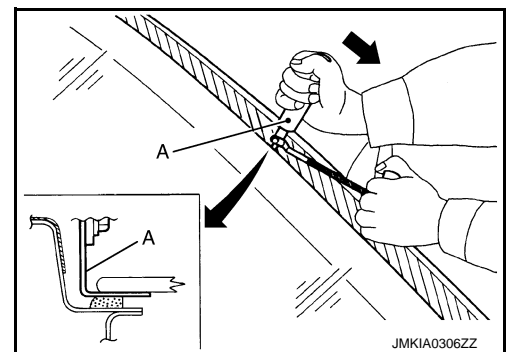

REAR WINDOW GLASS

< REMOVAL AND INSTALLATION >

- Use suction lifter (A) or rubber suction cups, etc. to remove rear window glass from the vehicle.

CAUTION:

2 workers are required for removal in order to prevent damage.

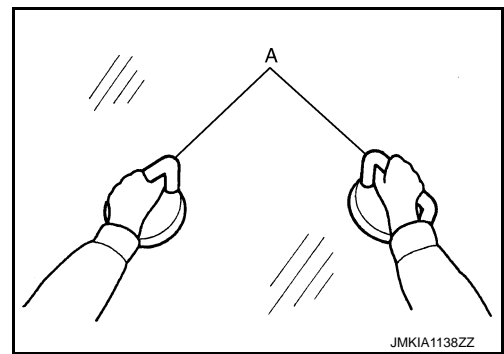

Reuse Rear Window Glass

CAUTION:

Never damage the rear window glass and body panel.

- Remove all assist grips.
Disengage assist grip cap fixing pawl using a remover tool (A), and then slide assist grip cap and remove it according to numerical order 1→2 indicated by arrows as shown in the figure.

 : Pawl

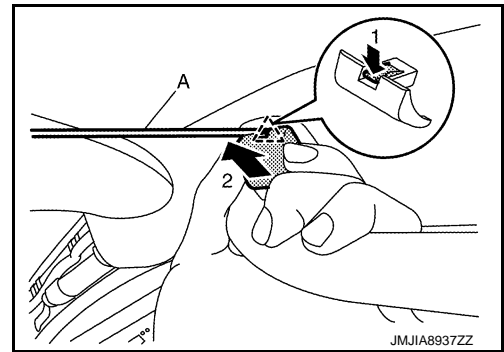

- Remove center pillar upper garnish (LH and RH). Refer to [INT-33. "CENTER PILLAR UPPER GARNISH: Removal and Installation"](#).
- Remove rear parcel shelf finisher. Refer to [INT-37. "Removal and Installation"](#).
- Disconnect rear window defogger connectors LH side (A) and RH side (B).

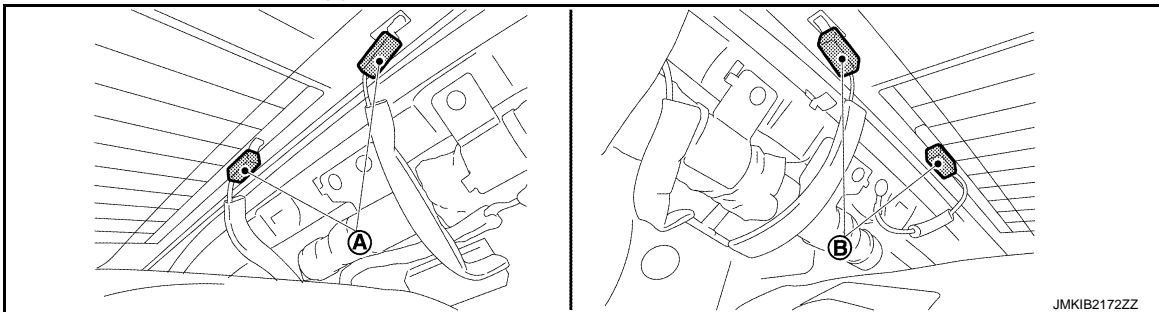

- Disengage fixing clips of headlining assembly rear end, and then pull down headlining assembly rear end.

CAUTION:

- 2 workers are required for removal in order to prevent damage.
- Never bend headlining when removing.

 : Clip

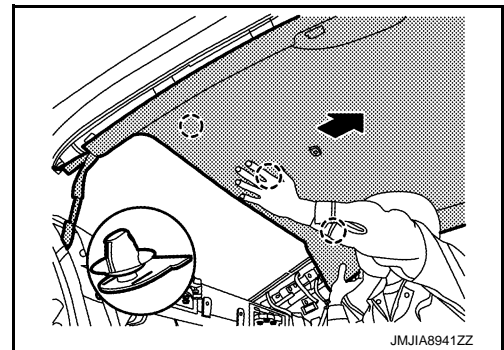

A
B
C
D
E
F
G
H
I
J
L
M
N
O
P

GW

REAR WINDOW GLASS

< REMOVAL AND INSTALLATION >

6. Apply protective tape (A) on body panel around rear window glass to protect painted surface from damage.

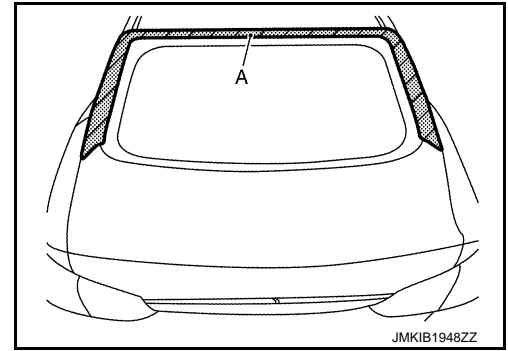

7. Paint matching marks on the rear window glass and body panel, positioning during installation can be easily performed.

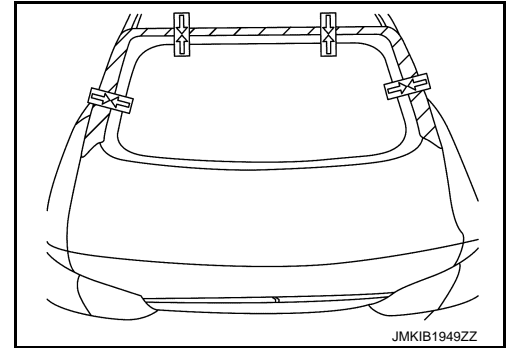

8. Cut the adhesive using a piano wire.

CAUTION:

Never use a windshield cutter if the rear window glass is reused. (It may scratch rear window glass surface)

- a. Pass the piano wire from passenger room to bonded area of glass using a wire pierce.

CAUTION:

- **Never press piano wire excessively against edge of rear window glass.**
- **For corner area, never insert piano wire into the mating surfaces of rear window glass.**
- **Never damage harness around rear window glass.**

- b. Tie both ends of the piano wire (B) to wire grip (A), etc.

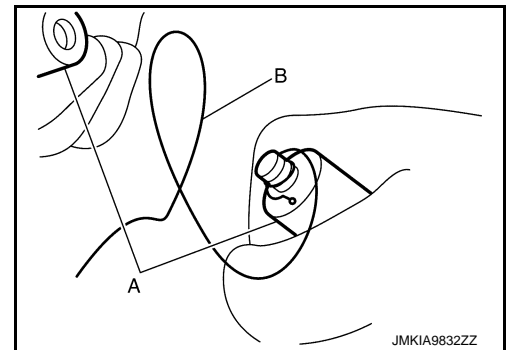

9. Use suction lifter (A) or rubber suction cups, etc. to remove rear window glass from the vehicle.

CAUTION:

2 workers are required for removal in order to prevent damage.

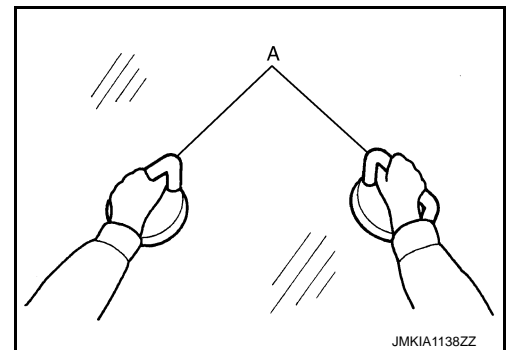

10. Remove rear window glass spacers after removing rear window glass.

REAR WINDOW GLASS

< REMOVAL AND INSTALLATION >

INSTALLATION

Replacement Rear Window Glass

1. Remove remaining adhesive and sealant using a scraper on the body side to approximately a depth that is 2 mm (0.079 in) thickness (A) so that entire contour becomes smooth.

CAUTION:

If the bonded area on the body is scratched, repair it using a 2 liquid type urethane paint. Never use lacquer type paint.

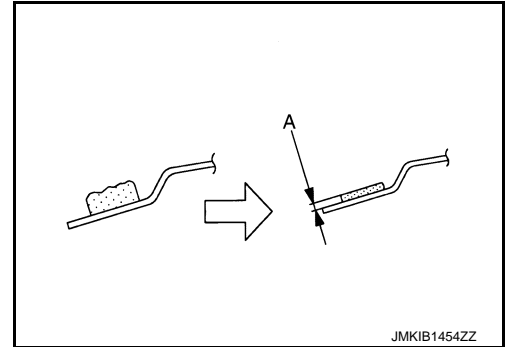

2. Mount rear window glass onto the vehicle and paint matching marks on body panel and rear window glass when installing new rear window glass. Then remove rear window glass again.
3. Use suction lifter (A) or rubber suction cups to set rear window glass ① on glass stand (B).

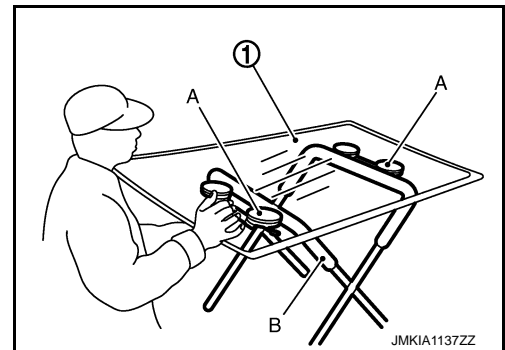

4. Clean the bonded area on rear window glass and body panel using a white gasoline or degreasing agent.
5. Install new rear window spacers to new rear window glass.
6. When installing new rear window glass ②, apply the dam sealant rubber ① from the edge of the rear window glass so as to hide the black print.

CAUTION:

Start to apply the dam sealant rubber at the outline mark of black print. Apply it so as to only place it without pulling. Stop applying at another outline mark of black print.

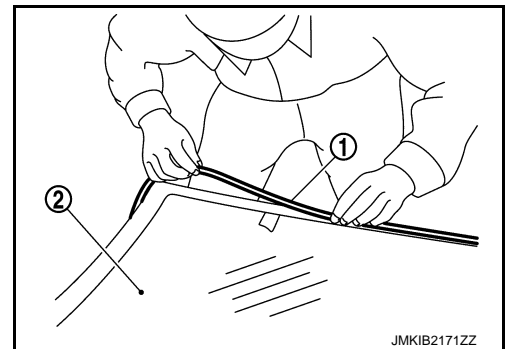

7. Apply primer for glass along the entire circumference of rear window glass. Use the sealing kit for glass application and the special holder for cartridge or similar tools.

CAUTION:

There are 2 types of primer. Never confuse the application methods.

- Primer for painted surfaces
- Primer for glass
- Apply primer for rear window glass and adhesive by following the black print marks on rear window glass.

NOTE:

The essential function of primers is to strengthen adhesion between rear window glass and painted surface.

8. Apply primer for the painted surface to the body side bonding surface.

CAUTION:

If the body side bonding surface is repaired with 2 liquid type urethane paint, always apply the primer after drying the paint.

A
B
C
D
E
F
G
H
I
J
GW
L
M
N
O
P

REAR WINDOW GLASS

< REMOVAL AND INSTALLATION >

- If primer for painted surfaces adheres to a painted surface other than the bonding area, or if it overflows, quickly remove it with white gasoline or degreasing agent.

9. Use sealant gun (A), affix the dam sealant rubber ① and apply adhesive ② along the edge of rear window glass within the time period indicated in the service manual after applying primer.

NOTE:

Open adhesive by cutting off the nozzle tip and set it in a sealant gun.

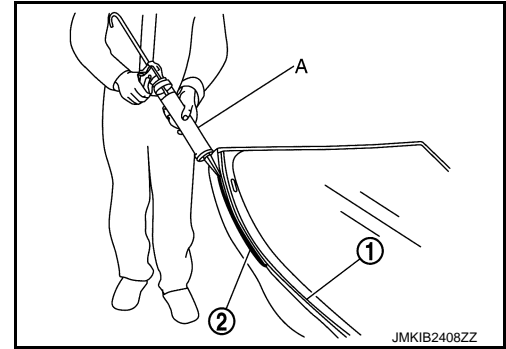

10. Use suction lifter (A) or rubber suction cups that are installed in advance, align the matching marks between the holder and roof panel hole and between the body panel and rear window glass ① to install them on the vehicle.

CAUTION:

2 workers are required when installing rear window glass.

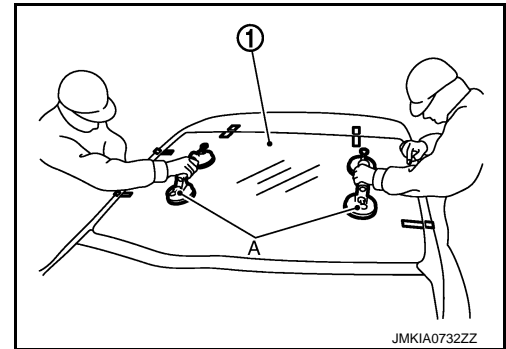

11. Press entire surface of glass lightly to fit it completely.
12. Correct any adhesive overflow or shortage using a spatula to make the surface smooth.
13. Remove protective tape.
14. Install the removed parts.

CAUTION:

- Check the mating area with surrounding parts. Adjust if necessary.
- After installation rear window glass, perform the inspection. Refer to [GW-34, "Inspection"](#).

Reuse Rear Window Glass

1. Remove remaining adhesive and sealant using a scraper on the body side to approximately a depth that is 2 mm (0.079 in) thickness (A) so that entire contour becomes smooth.

CAUTION:

If the bonded area on the body is scratched, repair it using a 2 liquid type urethane paint. Never use lacquer type paint.

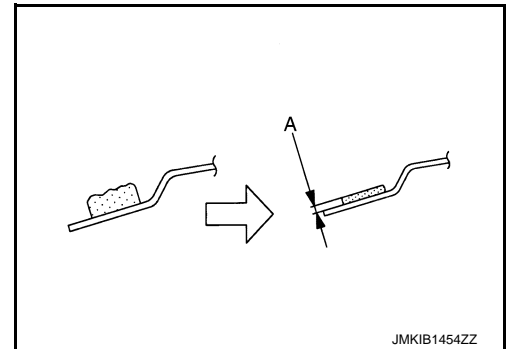

2. Remove remaining adhesive ① and sealant using a cutter (A) smooth out rear window glass surface ②.

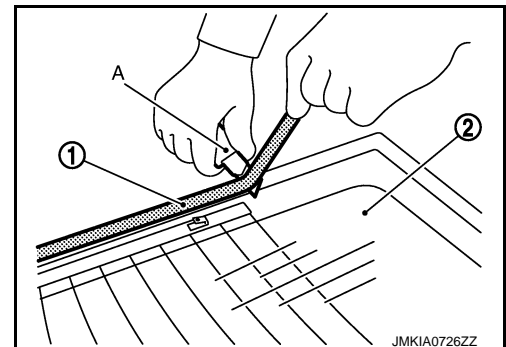

REAR WINDOW GLASS

< REMOVAL AND INSTALLATION >

3. Use suction lifter (A) or rubber suction cups to set rear window glass ① on glass stand (B).

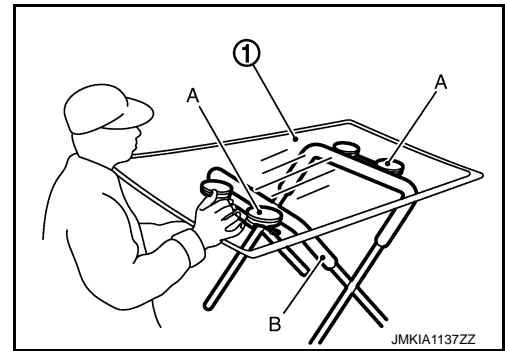

4. Clean the bonded area on rear window glass and body panel using a white gasoline or degreasing agent.
5. Install new rear window spacers to rear window glass.
6. When installing rear window glass ②, apply the dam sealant rubber ① from the edge of the rear window glass so as to hide the black print.

CAUTION:

Start to apply the dam sealant rubber at the outline mark of black print. Apply it so as to only place it without pulling. Stop applying at another outline mark of black print.

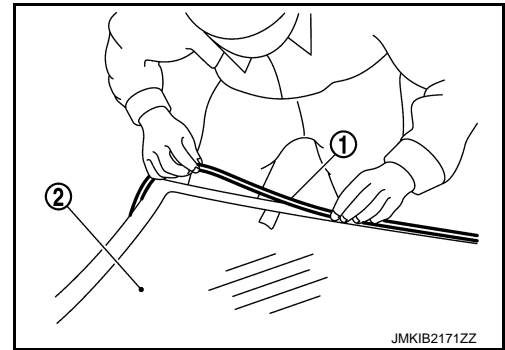

7. Apply primer for glass along the entire circumference of rear window glass. Use the sealing kit for glass application and the special holder for cartridge or similar tools.

CAUTION:

There are 2 types of primer. Never confuse the application methods.

- Primer for painted surfaces
- Primer for glass
- Apply primer for rear window glass and adhesive by following the black print marks on rear window glass.

NOTE:

The essential function of primers is to strengthen adhesion between rear window glass and painted surface.

8. Apply primer for the painted surface to the body side bonding surface.

CAUTION:

- If the body side bonding surface is repaired with 2 liquid type urethane paint, always apply the primer after drying the paint.
- If primer for painted surfaces adheres to a painted surface other than the bonding area, or if it overflows, quickly remove it with white gasoline or degreasing agent.

9. Use sealant gun (A), affix the dam sealant rubber ① and apply adhesive ② along the edge of rear window glass within the time period indicated in the service manual after applying primer.

NOTE:

Open adhesive by cutting off the nozzle tip and set it in a sealant gun.

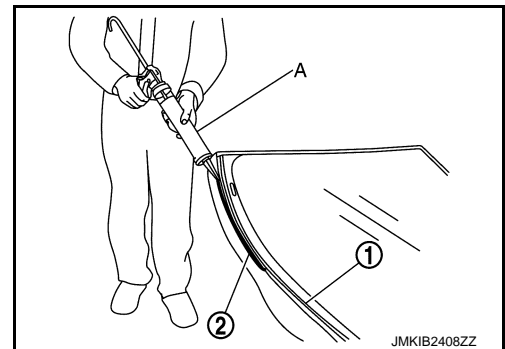

A
B
C
D
E
F
G
H
I
J
L
M
N
O
P

GW

REAR WINDOW GLASS

< REMOVAL AND INSTALLATION >

10. Use suction lifter (A) or rubber suction cups that are installed in advance, align the matching marks between the holder and roof panel hole and between the body panel and rear window glass ① to install them on the vehicle.

CAUTION:

2 workers are required when installing rear window glass.

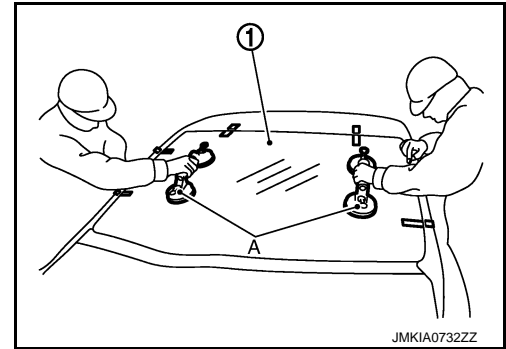

11. Press entire surface of glass lightly to fit it completely.
12. Correct any adhesive overflow or shortage using a spatula to make the surface smooth.
13. Remove protective tape.
14. Install the removed parts.

CAUTION:

- Check the mating area with surrounding parts. Adjust if necessary.
- After installation rear window glass, perform the inspection. Refer to [GW-34, "Inspection"](#).

Inspection

INFOID:0000000012794173

WATER LEAKAGE INSPECTION

CAUTION:

- Dry adhesive according to the specification of adhesive kit, do the leaking check when adhesive is stiffen.
- If leakage was found, start over from the beginning as rear window glass removal, install and leaking check.

FRONT DOOR GLASS

< REMOVAL AND INSTALLATION >

FRONT DOOR GLASS

Exploded View

INFOID:000000012794174

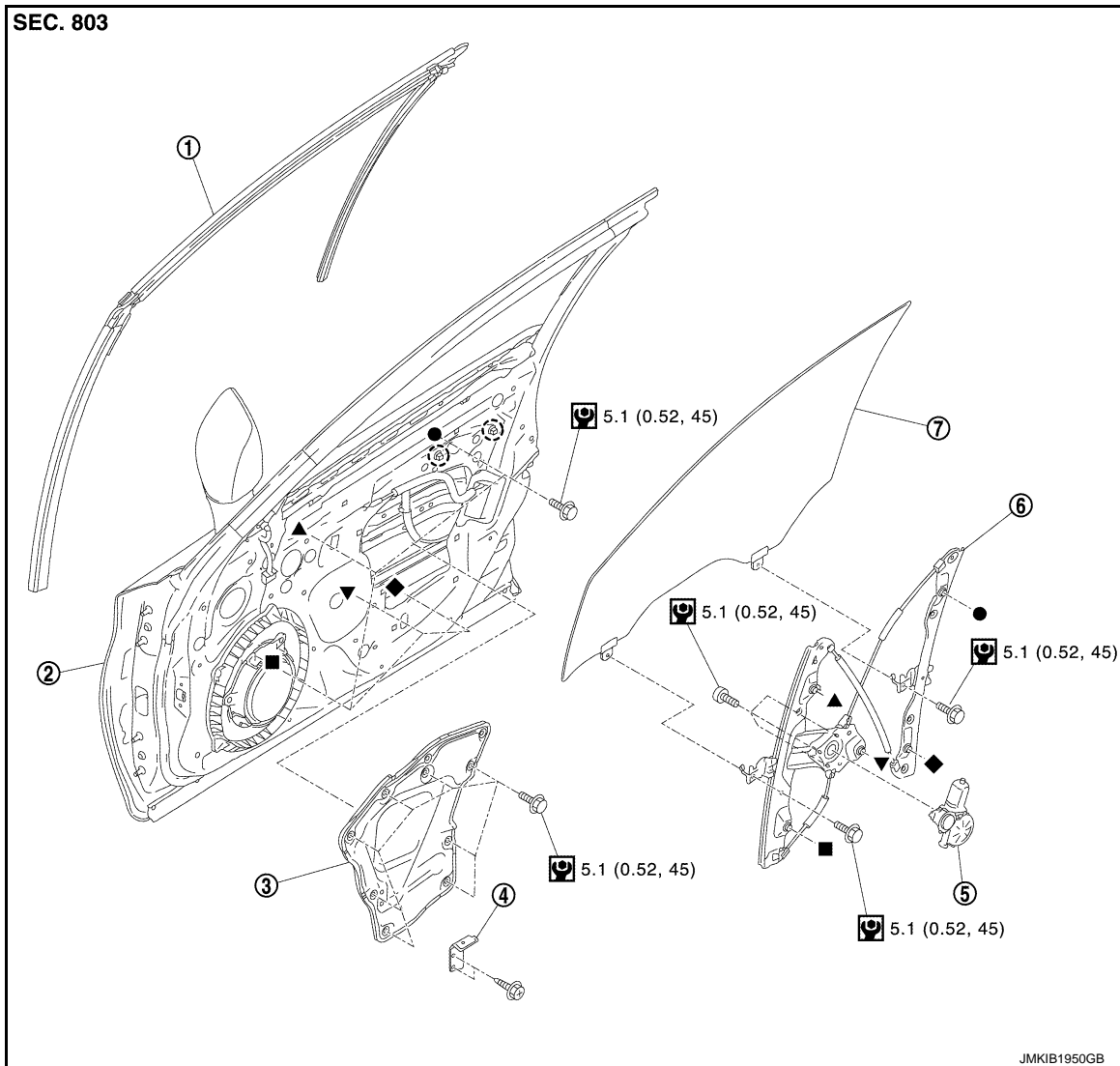

- | | | |
|----------------------------------|---------------------------------|--------------------------|
| ① Front door glass run | ② Front door panel | ③ Front door inner frame |
| ④ Front door pull handle bracket | ⑤ Front door power window motor | ⑥ Front door regulator |
| ⑦ Front door glass | | |

○ : Clip

⊕ : N·m (kg-m, in-lb)

●, ▲, ■, ▼, ◆: Indicates that the part is connected at points with same symbol in actual vehicle.

Removal and Installation

INFOID:000000012794175

REMOVAL

CAUTION:

Never damage the front door glass and front door panel.

- Fully open front door glass.
- Remove front door inside seal. Refer to [INT-17. "FRONT DOOR SASH INNER COVER : Removal and Installation"](#).

A
B
C
D
E
F
G
H
I
J
GW
L
M
N
O
P

FRONT DOOR GLASS

< REMOVAL AND INSTALLATION >

3. Disconnect front door woofer or front door speaker harness connector (A), and remove front door woofer or front door speaker mounting bolts (B), and then remove front door woofer or front door speaker.

NOTE:

- Front door woofer: With BOSE system
- Front door speaker: Without BOSE system

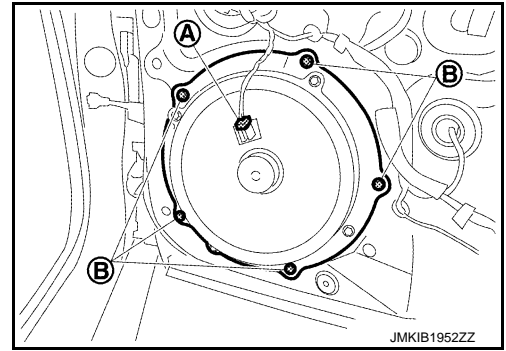

4. Remove front door inner frame mounting bolts (A) and fixing clips (B), and then remove front door inner frame.

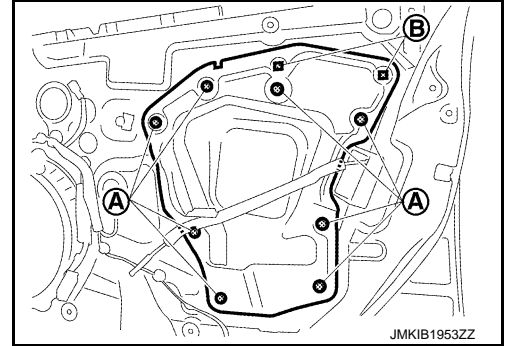

5. Reconnect power window main switch.

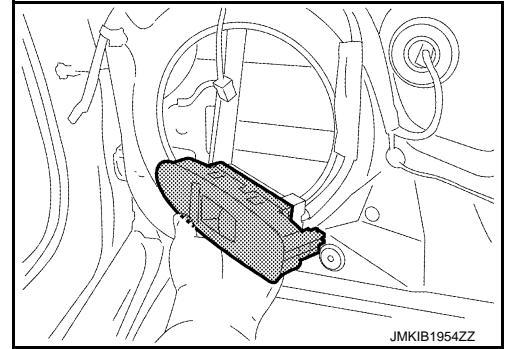

6. Operate power window main switch to raise or lower front door glass until front door glass mounting bolts (A) can be seen, and then remove front door glass mounting bolts.

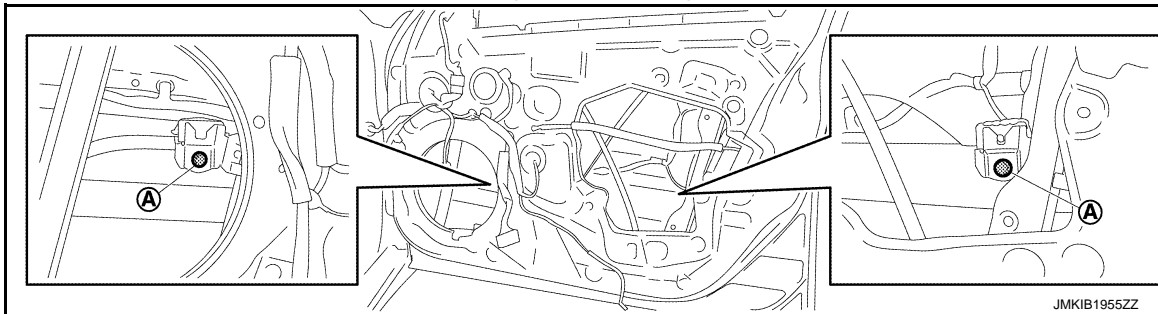

7. Hold securely front door glass and pull it out of front door panel to remove front door glass.

CAUTION:

Never damage front door glass, front door inner sash cover and front door panel.

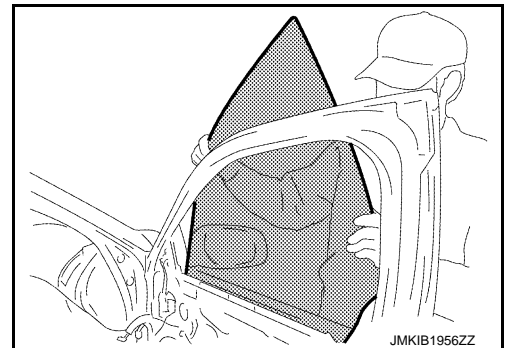

FRONT DOOR GLASS

< REMOVAL AND INSTALLATION >

8. Remove front door glass run after removing front door glass.
While pulling gradually front door glass run, and then remove front door glass run.

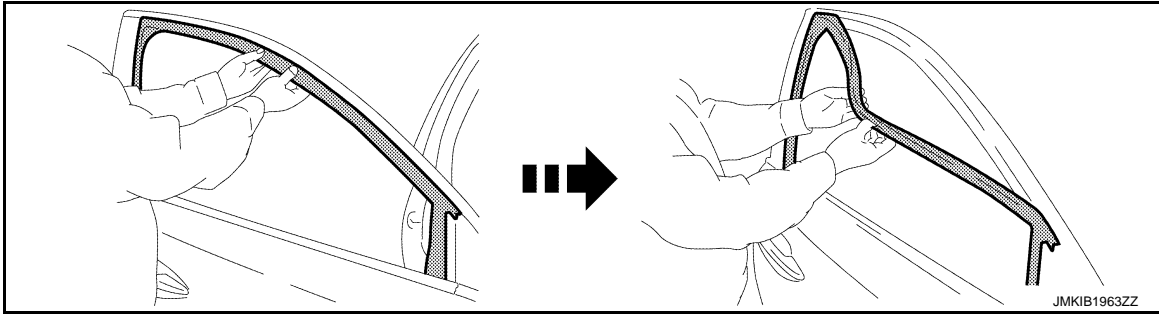

INSTALLATION

Note the following items, and then install in the reverse order of removal.

CAUTION:

- Tighten front door glass and front door inner frame mounting bolts to the specified torque. Refer to [GW-35, "Exploded View"](#).
- After installation front door glass, perform the inspection and adjustment. Refer to [GW-37, "Inspection and Adjustment"](#).

Inspection and Adjustment

INFOID:000000012794176

SYSTEM INITIALIZATION

Refer to [PWC-42, "Description"](#).

CHECK ANTI-PINCH FUNCTION

Refer to [PWC-43, "Description"](#).

FITTING INSPECTION

- Check that front door glass is fit securely into the sash groove.
- Lower front door glass slightly [approximately 10 to 20 mm (0.394 to 0.787 in)], and check that the clearance to the sash is parallel. Loosen the regulator mounting bolts, guide rail mounting bolts, and glass and guide rail mounting bolts to correct the glass position if the clearance between the glass and sash is not parallel.

A
B
C
D
E
F
G
H
I
J
L
M
N
O
P

GW

FRONT REGULATOR

< REMOVAL AND INSTALLATION >

FRONT REGULATOR

Exploded View

INFOID:000000012794177

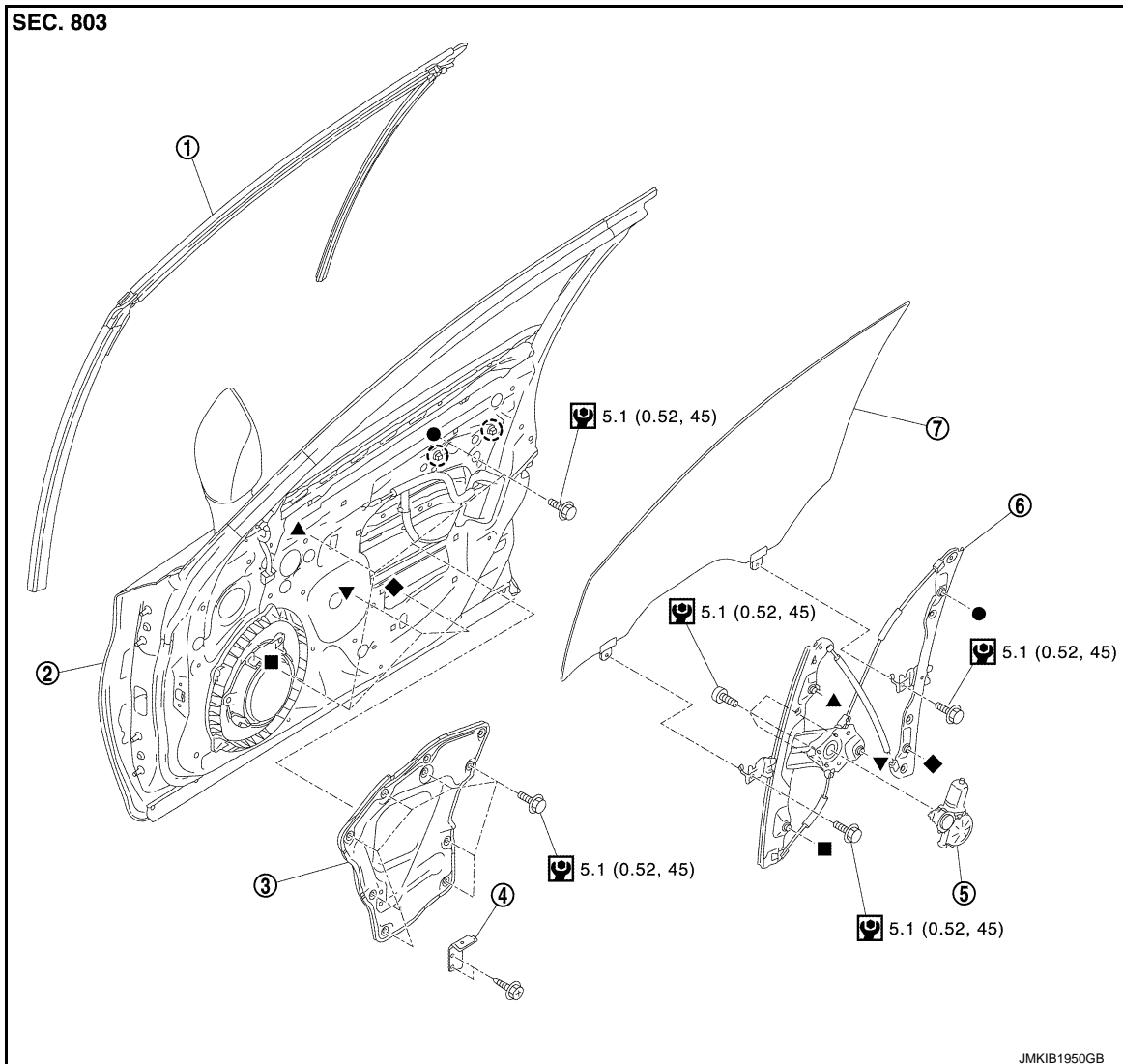

- | | | |
|----------------------------------|---------------------------------|--------------------------|
| ① Front door glass run | ② Front door panel | ③ Front door inner frame |
| ④ Front door pull handle bracket | ⑤ Front door power window motor | ⑥ Front door regulator |
| ⑦ Front door glass | | |

○ : Clip

⊙ : N·m (kg·m, in·lb)

●, ▲, ■, ▼, ◆: Indicates that the part is connected at points with same symbol in actual vehicle.

Removal and Installation

INFOID:000000012794178

REMOVAL

CAUTION:

Never damage the front door glass and front door panel.

1. Remove front door glass. Refer to [GW-35, "Removal and Installation"](#).

FRONT REGULATOR

< REMOVAL AND INSTALLATION >

2. Disconnect front door power window motor harness connector (A).

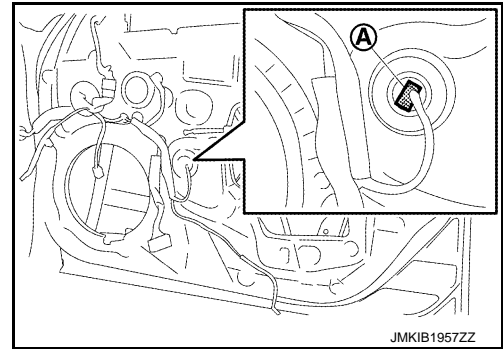

3. Remove front door regulator assembly mounting bolts (A).

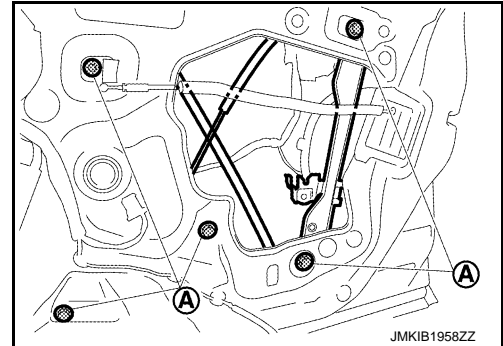

4. Peel off EPT seal.

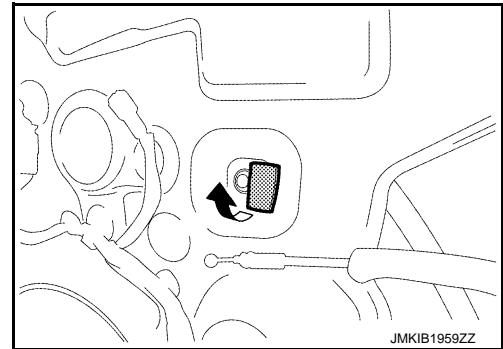

5. Disengage front door regulator assembly fitting portion according to numerical order 1→2 indicated by arrows as shown in the figure.

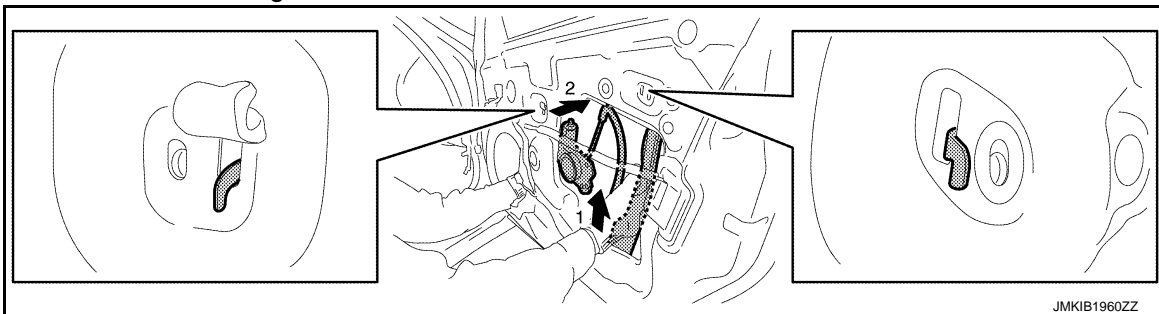

A
B
C
D
E
F
G
H
I
J
GW
L
M
N
O
P

FRONT REGULATOR

< REMOVAL AND INSTALLATION >

6. Remove front door regulator assembly according to numerical order 1→3 indicated by arrows as shown in the figure.

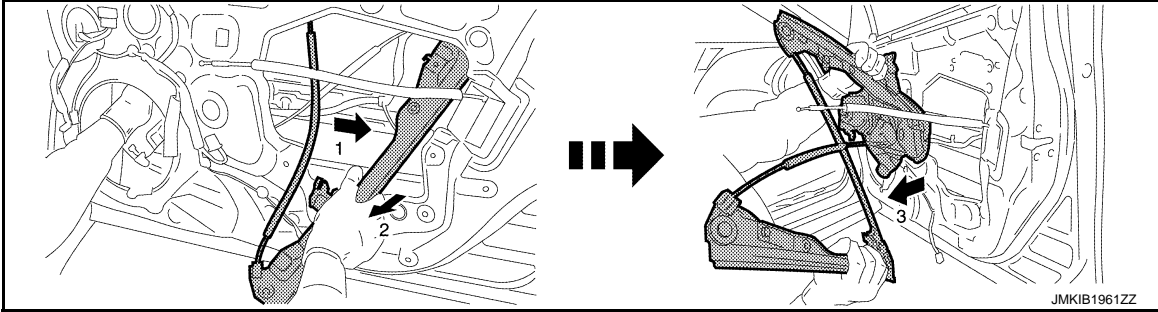

INSTALLATION

Note the following item, and then install in the reverse order of removal.

CAUTION:

- Tighten front door regulator assembly mounting bolts to the specified torque. Refer to [GW-38, "Exploded View"](#).
- After installation front door regulator assembly, perform the inspection and adjustment. Refer to [GW-40, "Inspection and Adjustment"](#).

Disassembly and Assembly

INFOID:000000012794179

DISASSEMBLY

1. Remove front door regulator assembly. Refer to [GW-38, "Removal and Installation"](#).
2. Remove front door power window motor mounting bolts (A), and then remove front door power window motor (1).

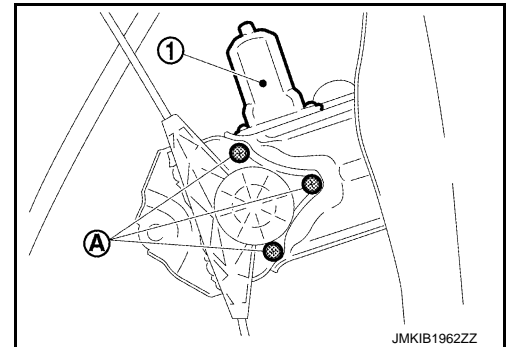

ASSEMBLY

Note the following item, and then assemble in the reverse order of disassembly.

CAUTION:

- Tighten front door power window motor mounting bolts to the specified torque. Refer to [GW-38, "Exploded View"](#).

Inspection and Adjustment

INFOID:000000012794180

SYSTEM INITIALIZATION

- Description. Refer to [PWC-42, "Description"](#).
- Work procedure. Refer to [PWC-42, "Work Procedure"](#).

CHECK ANTI-PINCH FUNCTION

- Description. Refer to [PWC-43, "Description"](#).
- Work procedure. Refer to [PWC-43, "Work Procedure"](#).

FITTING INSPECTION

- Check that the glass is fit securely into the sash groove.
- Lower the glass slightly [approximately 10 to 20 mm (0.394 to 0.787 in)], and check that the clearance to the sash is parallel. Loosen the regulator mounting bolts, guide rail mounting bolts, and glass and guide rail mounting bolts to correct the glass position if the clearance between the glass and sash is not parallel.

REAR DOOR GLASS

< REMOVAL AND INSTALLATION >

REAR DOOR GLASS

Exploded View

INFOID:000000012794181

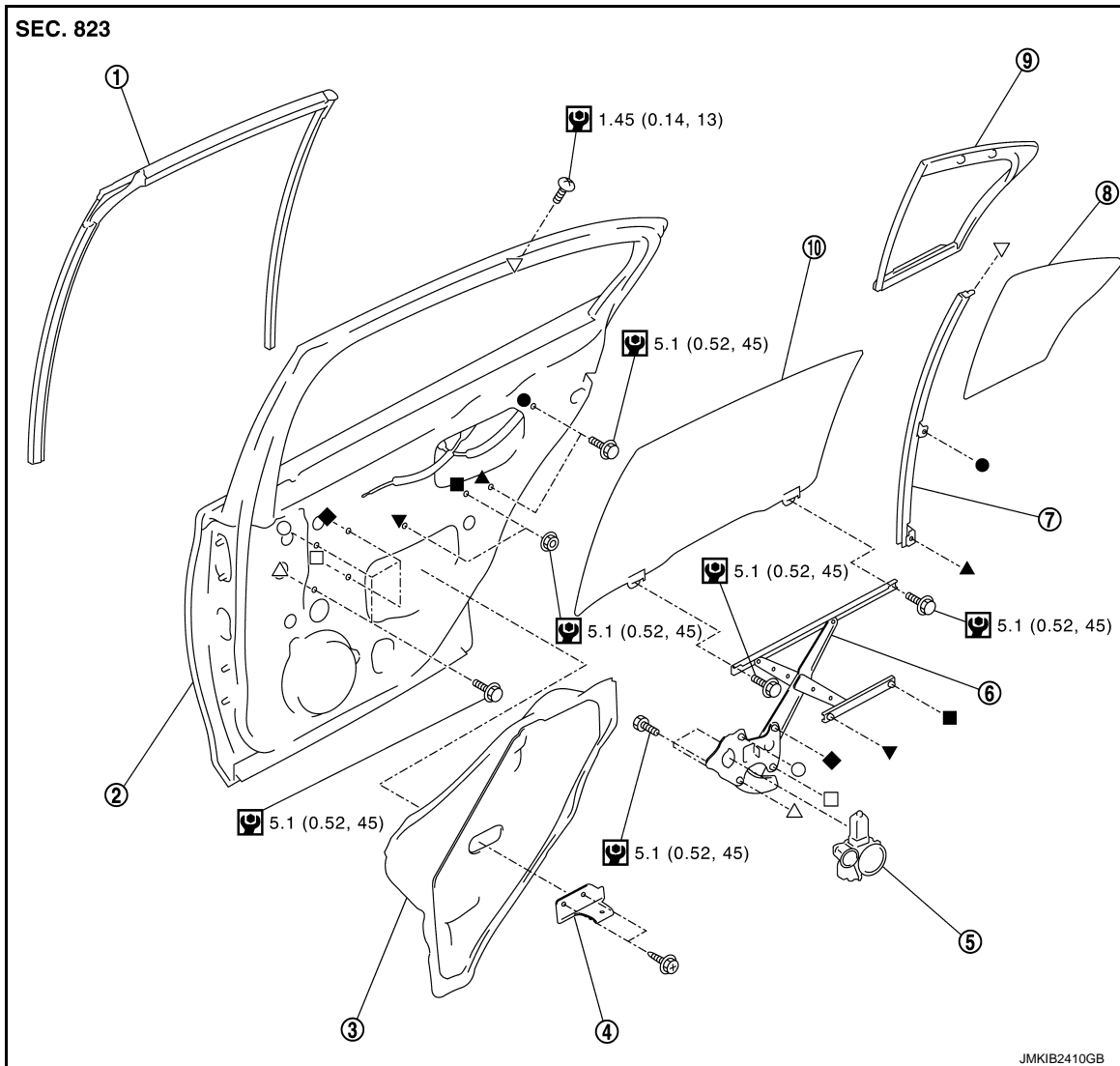

- | | | |
|---------------------------------|--------------------------------|---|
| ① Rear door glass run | ② Rear door panel | ③ Rear door sealing screen |
| ④ Rear door pull handle bracket | ⑤ Rear door power window motor | ⑥ Rear door regulator |
| ⑦ Rear door partition sash | ⑧ Rear door partition glass | ⑨ Rear door partition glass weather-strip |
| ⑩ Rear door glass | | |

☐ : N·m (kg-m, in-lb)

●, ▲, ■, ▼, ◆, ○, △, □, ▽: Indicates that the part is connected at points with same symbol in actual vehicle.

Removal and Installation

INFOID:000000012794182

REMOVAL

CAUTION:

Never damage the rear door glass and rear door panel.

1. Fully open rear door glass.
2. Remove rear door inner sash cover. Refer to [INT-22. "REAR DOOR SASH INNER COVER : Removal and Installation"](#).

A
B
C
D
E
F
G
H
I
J
GW
L
M
N
O
P

REAR DOOR GLASS

< REMOVAL AND INSTALLATION >

3. Disconnect rear door speaker harness connector (A), and remove rear door speaker mounting bolts (B), and then remove rear door speaker.

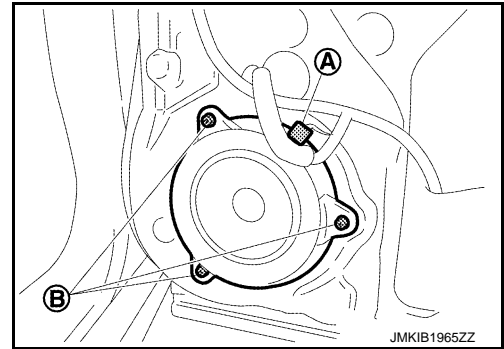

4. Disconnect rear door power window motor harness connector (A) and disengage rear door power window motor harness fixing clips (B).

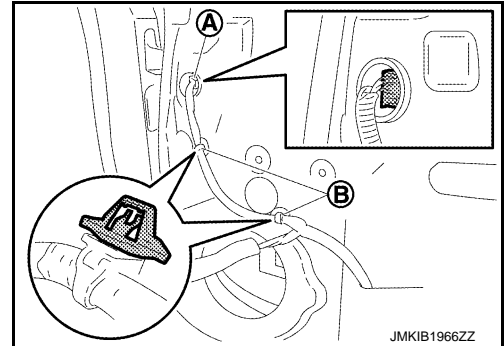

5. Remove rear door pull handle bracket fixing screws (A), and then remove rear door pull handle bracket.

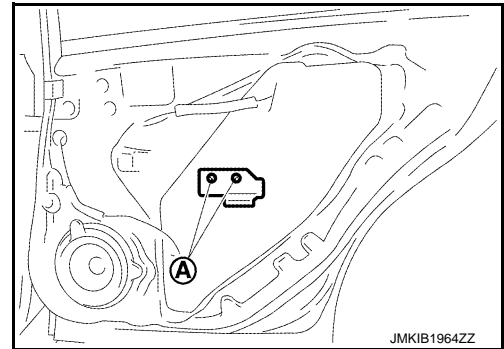

6. Peel off rear door sealing screen using a cutter-knife (A).

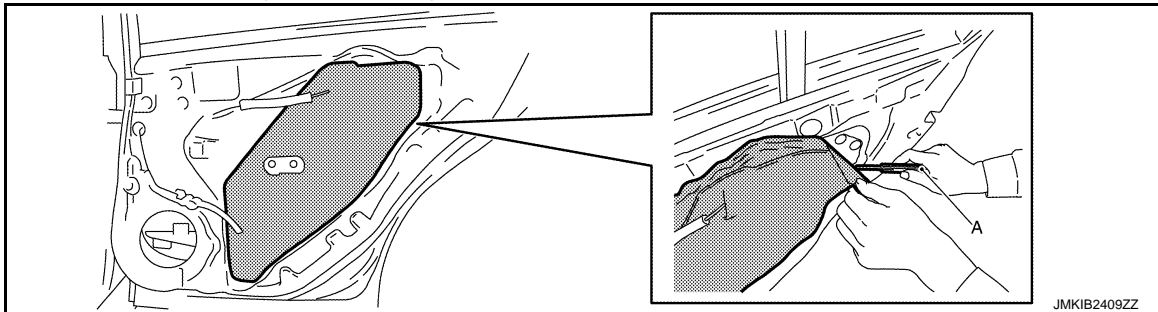

NOTE:

Cut the butyl-tape so that some parts of the butyl-tape do not remain on rear door sealing screen, if the rear door sealing screen is reused.

REAR DOOR GLASS

< REMOVAL AND INSTALLATION >

7. While pulling gradually rear door glass run, and then remove rear door glass run.

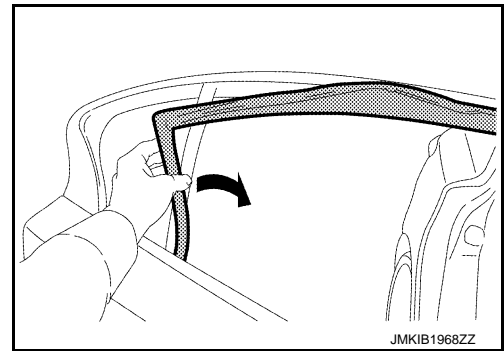

8. Remove rear door partition sash fixing screw (A) and mounting bolts (B).

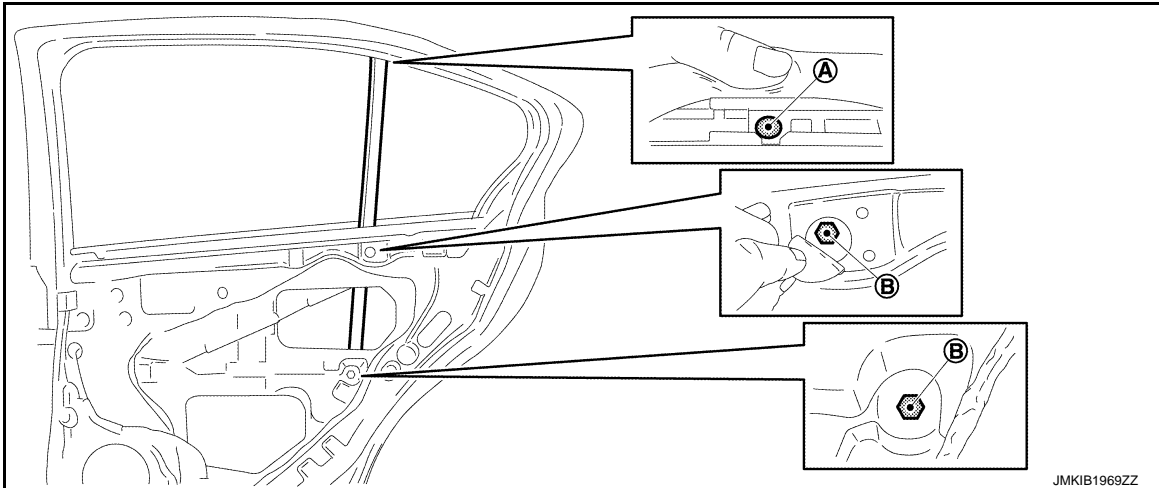

9. Remove rear door partition sash according to numerical order 1→2 indicated by arrows as shown in the figure, and then remove rear door partition sash.

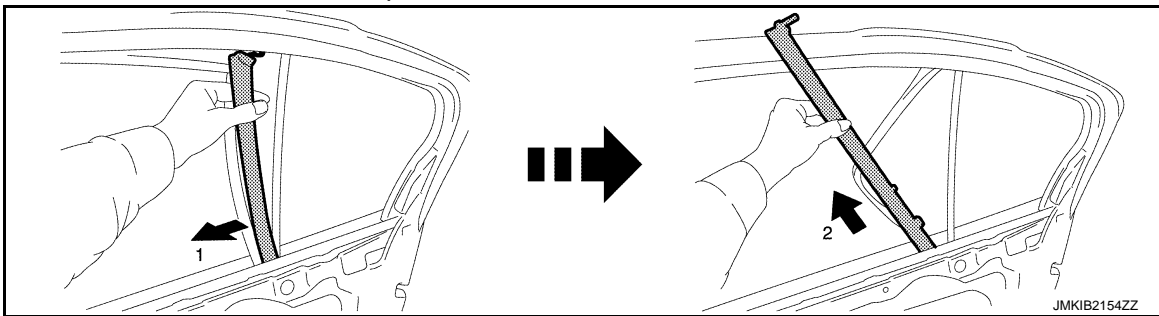

10. Reconnect rear door power window motor harness connector (A) and power window switch (1).

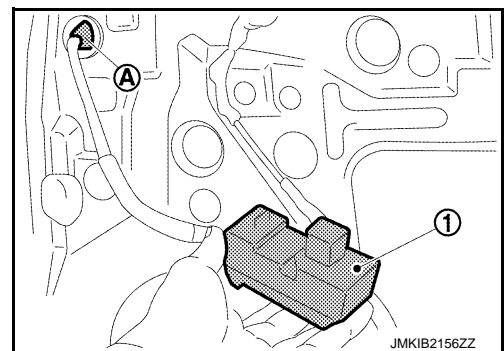

A
B
C
D
E
F
G
H
I
J
L
M
N
O
P

GW

REAR DOOR GLASS

< REMOVAL AND INSTALLATION >

11. Operate power window switch to raise or lower rear door glass until rear door glass mounting bolts (A) can be seen, and then remove rear door glass mounting bolts.

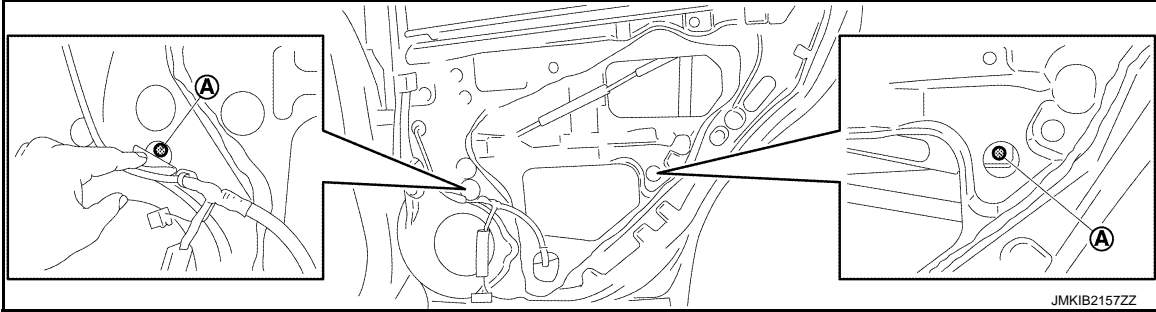

12. Hold securely rear door glass and pull it out of rear door panel to remove rear door glass.

CAUTION:

Never damage rear door glass, rear door partition glass and rear door panel.

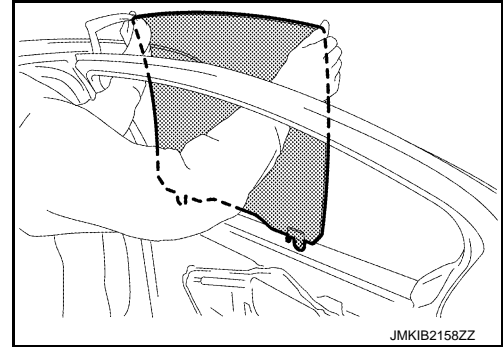

13. Remove rear door partition glass.

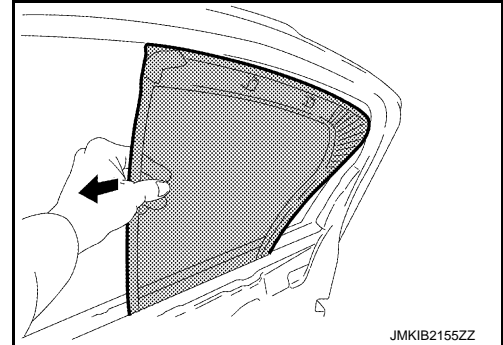

INSTALLATION

Note the following item, and then install in the reverse order of removal.

CAUTION:

- Tighten rear door partition sash fixing screw and mounting bolts and rear door glass mounting bolts to the specified torque. Refer to [GW-41, "Exploded View"](#).
- After installation rear door glass, perform the inspection and adjustment. Refer to [GW-44, "Inspection and Adjustment"](#).

Inspection and Adjustment

INFOID:000000012794183

SYSTEM INITIALIZATION

Refer to [PWC-42, "Description"](#).

CHECK ANTI-PINCH FUNCTION

Refer to [PWC-43, "Description"](#).

FITTING INSPECTION

- Check that the glass is fit securely into the sash groove.
- Lower the glass slightly [approximately 10 to 20 mm (0.394 to 0.787 in)], and check that the clearance to the sash is parallel. Loosen the regulator mounting bolts, guide rail mounting bolts, and glass and guide rail mounting bolts to correct the glass position if the clearance between the glass and sash is not parallel.

REAR REGULATOR

< REMOVAL AND INSTALLATION >

REAR REGULATOR

Exploded View

INFOID:000000012794184

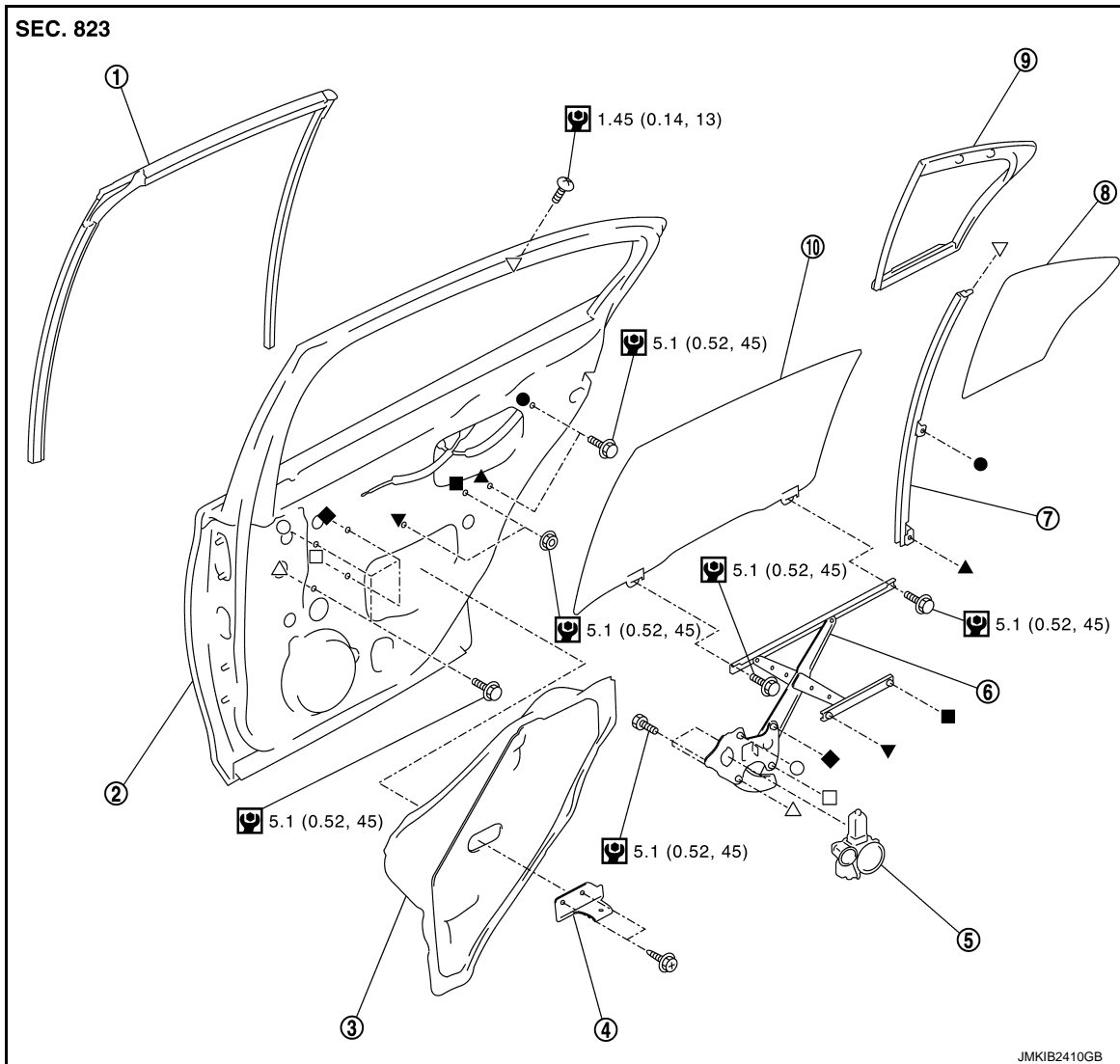

- | | | |
|---------------------------------|--------------------------------|---|
| ① Rear door glass run | ② Rear door panel | ③ Rear door sealing screen |
| ④ Rear door pull handle bracket | ⑤ Rear door power window motor | ⑥ Rear door regulator |
| ⑦ Rear door partition sash | ⑧ Rear door partition glass | ⑨ Rear door partition glass weather-strip |

⑩ Rear door glass

☐ : N·m (kg·m, in·lb)

●, ▲, ■, ▼, ◆, ○, △, □, ▽: Indicates that the part is connected at points with same symbol in actual vehicle.

Removal and Installation

INFOID:000000012794185

REMOVAL

CAUTION:

Never damage the rear door glass and rear door panel.

1. Remove rear door glass. Refer to [GW-41. "Removal and Installation"](#).

REAR REGULATOR

< REMOVAL AND INSTALLATION >

2. Disconnect rear door power window motor harness connector (A).

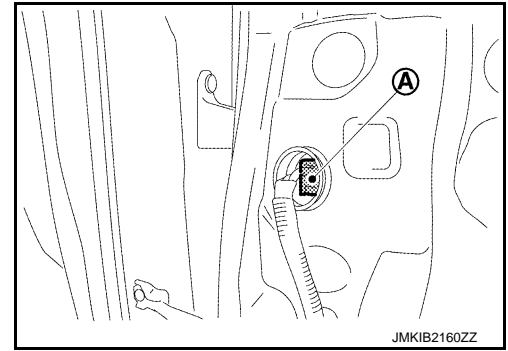

3. Remove rear door regulator assembly mounting bolts (A) and nuts (B).

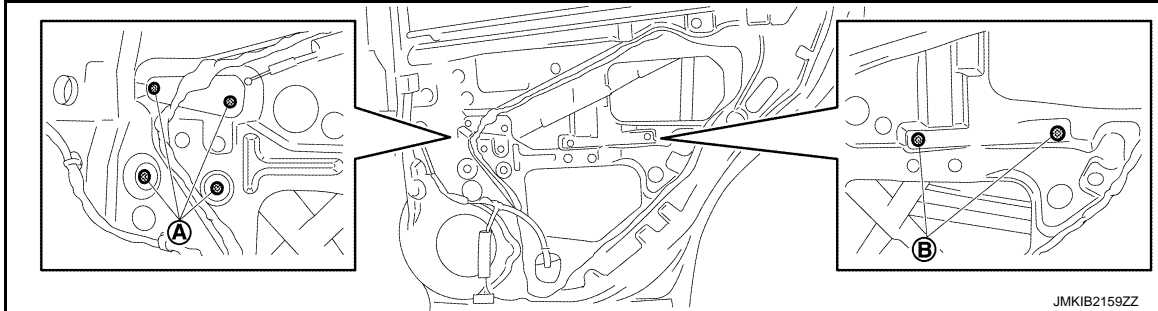

4. Remove rear door regulator assembly according to numerical order 1→3 indicated by arrows as shown in the figure, and then remove rear door regulator assembly.

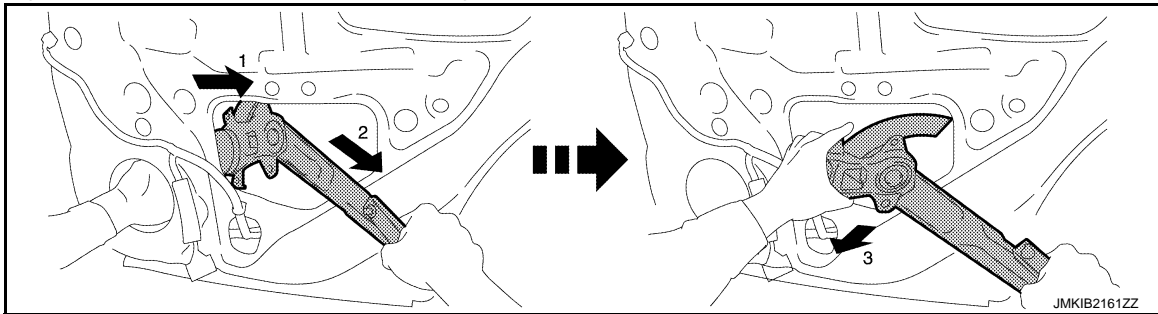

INSTALLATION

Note the following item, and then install in the reverse order of removal.

CAUTION:

- Tighten rear door regulator assembly mounting bolts and nuts to the specified torque. Refer to [GW-45, "Exploded View"](#).
- After installation rear door regulator assembly, perform the inspection and adjustment. Refer to [GW-47, "Inspection and Adjustment"](#).

Disassembly and Assembly

INFOID:000000012794186

DISASSEMBLY

1. Remove rear door regulator assembly. Refer to [GW-45, "Removal and Installation"](#).
2. Remove rear door power window motor mounting bolts (A), and then remove rear door power window motor (1).

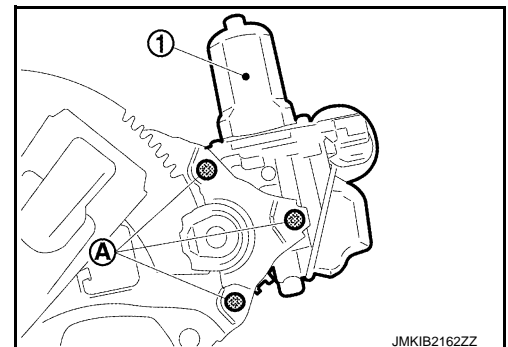

REAR REGULATOR

< REMOVAL AND INSTALLATION >

ASSEMBLY

Note the following item, and then assemble in the reverse order of disassembly.

CAUTION:

Tighten rear door power window motor mounting bolts to the specified torque. Refer to [GW-45](#), "[Exploded View](#)".

Inspection and Adjustment

INFOID:000000012794187

SYSTEM INITIALIZATION

- Description. Refer to [PWC-42](#), "[Description](#)".
- Work procedure. Refer to [PWC-42](#), "[Work Procedure](#)".

CHECK ANTI-PINCH FUNCTION

- Description. Refer to [PWC-43](#), "[Description](#)".
- Work procedure. Refer to [PWC-43](#), "[Work Procedure](#)".

FITTING INSPECTION

- Check that the glass is fit securely into the sash groove.
- Lower the glass slightly [approximately 10 to 20 mm (0.394 to 0.787 in)], and check that the clearance to the sash is parallel. Loosen the regulator mounting bolts, guide rail mounting bolts, and glass and guide rail mounting bolts to correct the glass position if the clearance between the glass and sash is not parallel.

A
B
C
D
E
F
G
H
I
J
L
M
N
O
P

GW